

PROSTHETIC MANUAL

for Izenimplant System



PROSTHETIC MANUAL

for Izenimplant System

CONTENTS

Restoration Introduction

- 6 ZENEX IMPLANT SYSTEM
- 9 ZENEX System Overview
- 10 Prosthetic Type
- 11 Impression Type
- 12 Tightening Torque
- 13 Prosthetic Guide
- 14 Component & Instrument
- 16 Right Connection Checking Guide
- 23 Prosthetic Connection Chart by Diameter
- 24 ZENEX MULTI/PLUS Fixture Driver Instructions



29p

Cemented
Abutment

- 31 **Step 1** Separation of Cover Screw or Healing Abutment
- 32 **Step 2** Connect the Impression Coping
- 34 **Step 3** Impression Taking & Connect the Lab Analog
- 36 **Step 4** Working Model Production
- 37 **Step 5** Wax-Up, Casting & Porcelain Build-Up
- 38 **Step 6** Transfer Jig Production
- 39 **Step 7** Fastening of intraoral Abutment & installation of prosthesis



41p

Angled
Abutment

- 43 **Step 1** Separation of Cover Screw or Healing Abutment
- 43 **Step 2** Connect the Impression Coping
- 44 **Step 3** Impression Taking & Connect the Lab Analog
- 45 **Step 4** Working Model Production
- 45 **Step 5** Wax-Up, Casting & Porcelain Build-Up
- 46 **Step 6** Transfer Jig Production
- 47 **Step 7** Fastening of Abutment in oral cavity & installation of prosthesis



49p

FreeMilling
Abutment

- 51 **Step 1** Separation of Cover Screw or Healing Abutment
- 51 **Step 2** Connect the Impression Coping
- 53 **Step 3** Impression Taking & Connect the Lab Analog
- 55 **Step 4** Working Model Production and Abutment Milling
- 56 **Step 5** Wax-Up, Casting & Porcelain Build-Up
- 57 **Step 6** Transfer Jig Production
- 58 **Step 7** Fastening of Abutment in oral cavity & installation of prosthesis



59p

CCM Cast
Abutment

- 61 **Step 1** Separation of Cover Screw or Healing Abutment
- 61 **Step 2** Connect the Impression Coping
- 62 **Step 3** Impression Taking
- 63 **Step 4** Fastening of Healing Abutment or Production of Temporary Abutment
- 64 **Step 5** Working Model Production
- 65 **Step 6** Wax-Up
- 66 **Step 7** Casting
- 67 **Step 8** Porcelain build up
- 68 **Step 9** Oxide film removal
- 69 **Step 10** Fastening of intraoral Abutment & installation of prosthesis



71p

**Multi Straight
& Multi Angled
Abutment**

- 74 **Step 1** Separation of Cover Screw or Healing Abutment
- 75 **Step 2** Connect the Multi Straight & Multi Angled Abutment in the oral cavity
- 76 **Step 3** Connect the Impression Coping
- 77 **Step 4** Impression Taking
- 78 **Step 5** Working Model Production
- 79 **Step 6** Wax-Up
- 80 **Step 7** Casting
- 81 **Step 8** Porcelain build up
- 82 **Step 9** Oxide film removal
- 83 **Step 10** Ceramic Crown Production
- 84 **Step 11** Delivering & Screwing



87p

**Ball
Abutment**

- 89 **Step 1** Separation of Cover Screw or Healing Abutment
- 90 **Step 2** Connect the Ball Abutment in the oral cavity
- 91 **Step 3** Impression Taking
- 92 **Step 4** Working Model Production
- 92 **Step 5** Wax Denture Production
- 93 **Step 6** Resin denture Production
- 95 **Step 7** Delivering



97p

**Ti Link
Abutment**

- 99 **Step 1** Separation of Cover Screw or Healing Abutment
- 99 **Step 2** Impression Taking
- 101 **Step 3** Working Model Production
- 102 **Step 4** Scan
- 103 **Step 5** Design
- 103 **Step 6** Design confirm and processing
- 104 **Step 7** Sintering and post-processing
- 105 **Step 8** Bonding and completion of Abutment
- 106 **Step 9** Final prosthesis fabrication
- 106 **Step 10** Fastening of intraoral Abutment & installation of prosthesis



107p

**Ti Blank
Abutment**

- 109 **Step 1** Separation of Cover Screw or Healing Abutment
- 109 **Step 2** Impression Taking
- 111 **Step 3** Fastening of Healing Abutment or Production of Temporary Abutment
- 112 **Step 4** Working Model Production
- 112 **Step 5** Scan
- 113 **Step 6** Design
- 113 **Step 7** Design Confirm and processing
- 114 **Step 8** Post Processing
- 114 **Step 9** Connect the Customized Abutment
- 114 **Step 10** Wax-up
- 115 **Step 11** Casting
- 115 **Step 12** Ceramic Crown Product
- 116 **Step 13** Fastening of intraoral Abutment & installation of prosthesis

ZENEX IMPLANT SYSTEM

Designed for various types of bone

Post shape (Rounded top) optimized for digital dentistry system

Wide cross-section to prevent crown rotation and secure accurate placement

Wide marginal area to prevent crown fracture

Small screw guide hole to secure strength of abutment

Optimized abutment screw for Short Fixture

Platform Switching

Prevents crestal bone loss after implant placement and provides esthetic result

Two conical contact point

Strong tightening force of dual contact between fixture and abutment results in less sink-down which leads to preventing screw loosening

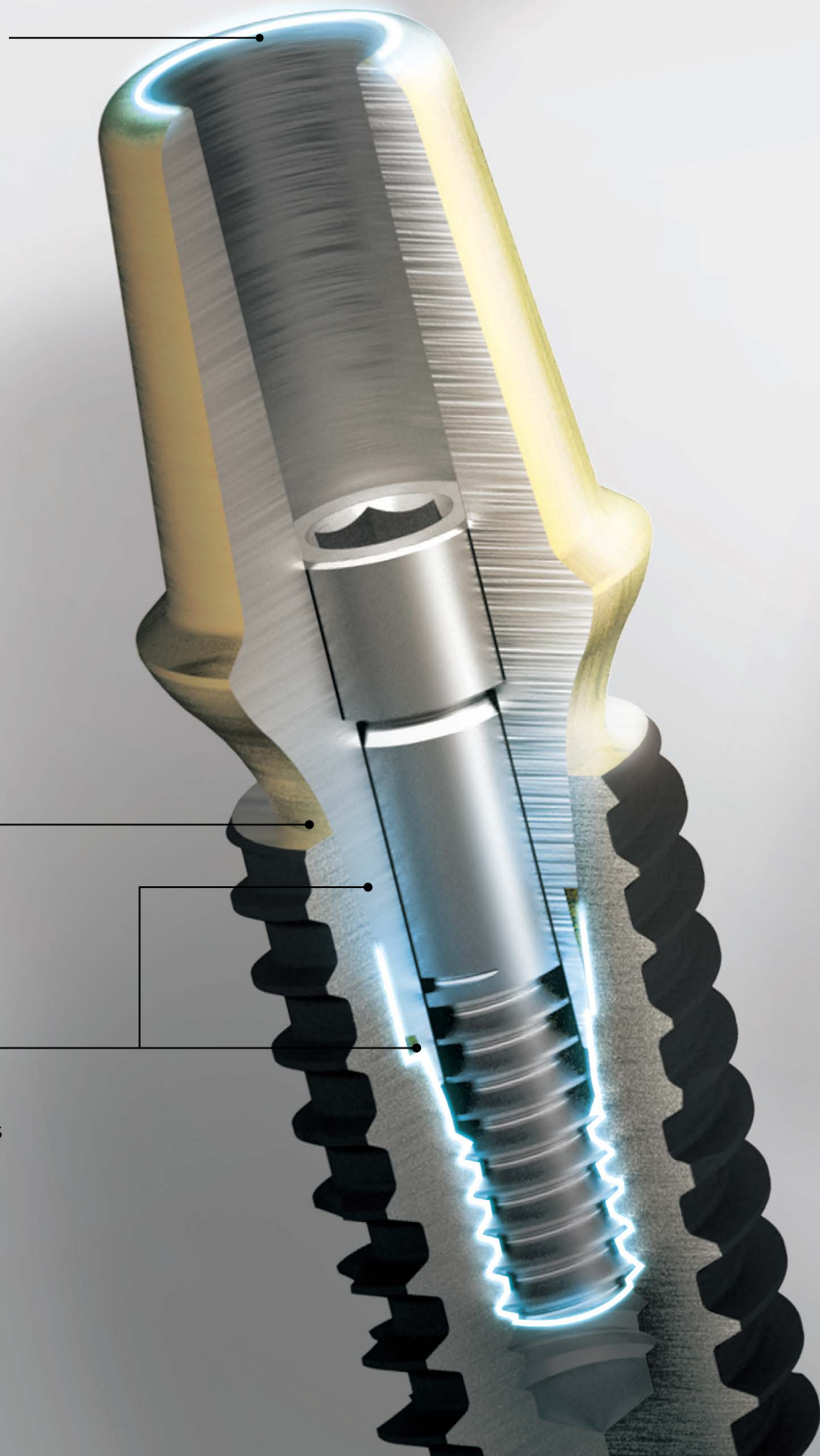

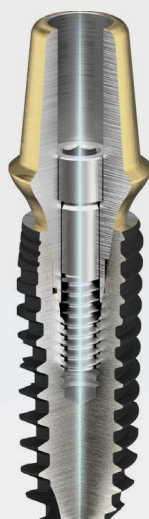

I system

1° tapered double contact connection design to prevent screw loosening

Small connection enables to use on narrow-width bone

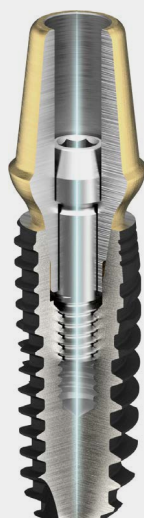

T system

Deep hex hole to prevent abutment rotation



R system

5° tapered connection to secure strong fixation Internal screw for easy tightening and separation of abutment

Stage

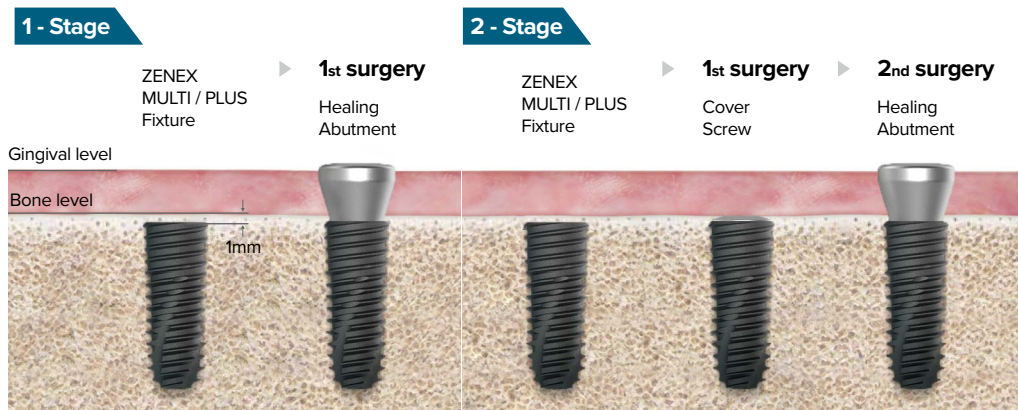

Cover Screw

Select appropriate Cover Screw height upon depth of implant placement.

Select specification fits for fixture connection.

Tighten with 1.2 Hex Driver by hand.

Recommended tightening torque: 5~8Ncm

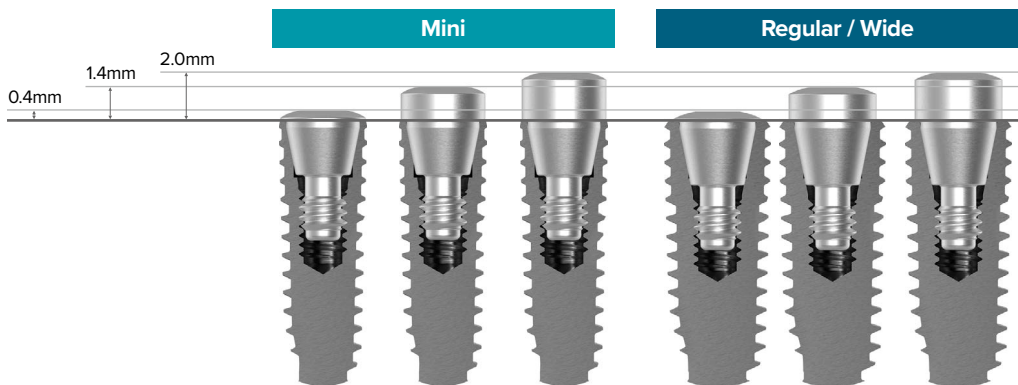

Healing Abutment

Use Healing Abutment fits for the diameter of abutment.

Use specification fits for fixture connection.

Tighten with 1.2 Hex Driver by hand.

Recommended tightening torque: 5~8Ncm

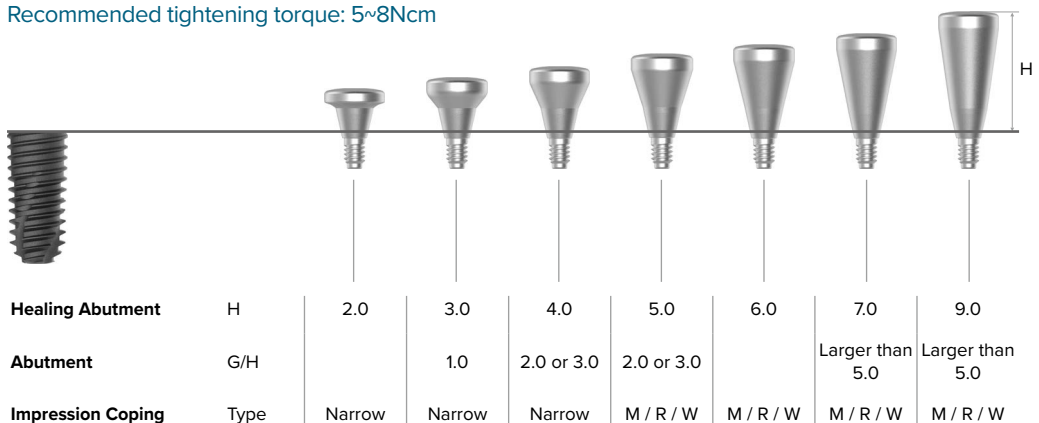

ZENEX System Overview

Single / Bridge Case



2-Piece

| Prosthetic Type | Abutment | Cemented Abutment | Angled Abutment | FreeMilling Abutment | CCM Cast Abutment |
|-----------------|----------|-------------------|-----------------|----------------------|-------------------|
| | Screw | | ✓ | ✓ | ✓ |
| Cement | | ✓ | ✓ | ✓ | ✓ |
| Combination | | ✓ | ✓ | ✓ | ✓ |

| Impression Type | Abutment | Cemented Abutment | Angled Abutment | FreeMilling Abutment | CCM Cast Abutment |
|-----------------|----------------|-------------------|-----------------|----------------------|-------------------|
| | Abutment Level | | x | x | x |
| Fixture Level | | ✓ | ✓ | ✓ | ✓ |

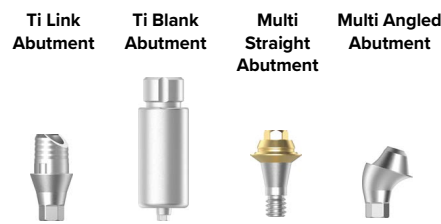

2-Piece

3-Piece

| Prosthetic Type | Abutment | Ti Link Abutment | Ti Blank Abutment | Multi Straight Abutment | Multi Angled Abutment |
|-----------------|----------|------------------|-------------------|-------------------------|-----------------------|
| | Screw | | ✓ | ✓ | x |
| Cement | | ✓ | ✓ | ✓ | ✓ |
| Combination | | ✓ | ✓ | ✓ | ✓ |

| Impression Type | Abutment | Ti Link Abutment | Ti Blank Abutment | Multi Straight Abutment | Multi Angled Abutment |
|-----------------|----------------|------------------|-------------------|-------------------------|-----------------------|
| | Abutment Level | | x | x | ✓ |
| Fixture Level | | ✓ | ✓ | x | x |

Overdenture Case

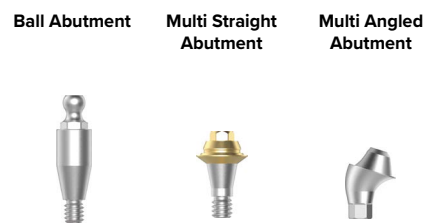

| Prosthetic Type | Abutment | Ball Abutment | Multi Straight Abutment | Multi Angled Abutment |
|-----------------|------------------|---------------|-------------------------|-----------------------|
| | Retentive Anchor | | ✓ | ✓ |
| Bar Frame | | ✓ | ✓ | ✓ |

| Impression Type | Abutment | Ball Abutment | Multi Straight Abutment | Multi Angled Abutment |
|-----------------|----------------|---------------|-------------------------|-----------------------|
| | Abutment Level | | ✓ | ✓ |
| Fixture Level | | x | x | x |

Single / Bridge Case

2 piece

Screw or cement or combination type prosthesis is possible with fixture level

Cemented / Angled / FreeMilling Abutment

Screw or cement or combination type prosthesis is possible with fixture level impression, can be customized depending on oral environment and prosthesis type

CCM Cast Abutment

Screw or cement or combination type prosthesis is possible with fixture level impression (need caution with casting, firing in screw type prosthesis fabrication)

Ti Blank/Ti Link Abutment

CAD/CAM product, fabricate customized abutment for patient using S/W in different oral environment and prosthesis type

3 piece

Multi Straight / Multi Angled Abutment

Cement or combination type prosthesis is possible with abutment level impression and effective in bridge case with unfavorable path

* Contents above are general guideline from the company and products must be selected in consideration of oral environment, habits, fixture placement condition, clinical experience and aftermath.

Overdenture Case

3 piece

Multi Straight / Multi Angled Abutment

Effective in the fabrication of overdenture using bar frame in abutment level impression

* Contents above are general guideline from the company and products must be selected in consideration of oral environment, habits, fixture placement condition, clinical experience and aftermath.

Prosthetic Type

Screw

Combined with abutment through casting and firing in fabrication process

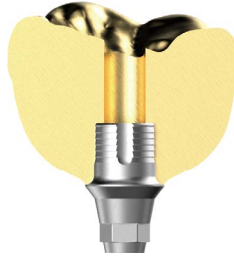

- Screw hole is exposed above occlusal surface, therefore esthetics and occlusion have to be considered
- Prosthesis can easily be removed with screw, therefore there is no side effects from cement
- Errors can occur in bridge fabrication in casting or firing process
- Setting is affected severely by the fixture angle and adjacent teeth

Cement

Casted or fired separately from abutment in the fabrication process, and combined by cement

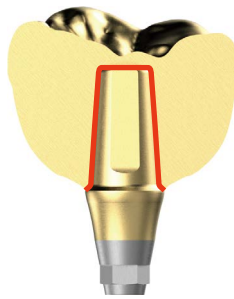

- There is no screw hole, therefore esthetic surface can be created
- Difficult to remove prosthesis
- Cement is difficult to remove and has chances for inflammation
- Passive fit in bridge is easy
- Relatively easy setting, only affected by adjacent teeth

Combination

· Casted or fired separately from abutment in the fabrication process, and combined by cement (same as cement type)

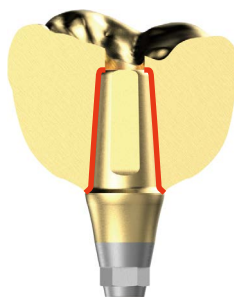

- Screw hole is exposed above occlusal surface, therefore esthetics and occlusion have to be considered
- Maintenance is easy because prosthesis can easily be removed with screw
- After connecting prosthesis with cement, cement can be removed completely outside the mouth, so there is no side effect from cement
- Passive fit in bridge is easy
- Setting is affected by the fixture angle and adjacent teeth but relatively easy compared to screw type

Impression Type

Abutment Level Impression

- Similar impression taking as natural teeth
- Bring abutment shape/position to working model (Impression taking is based on abutment information)
- Prosthetic process is relatively easy and convenient
- Close tray (ready made / stock tray) used
- Exclusive impression coping for each abutment is recommended

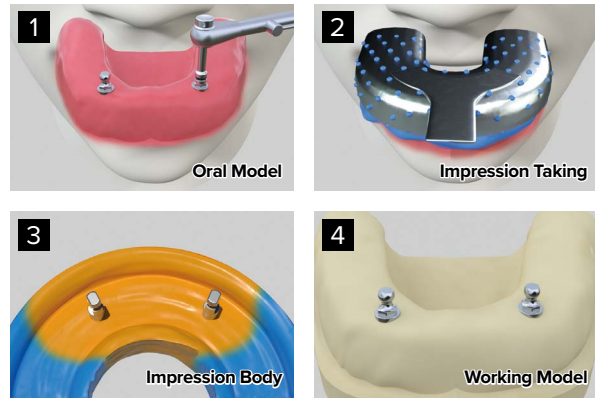

Fixture Level Impression Pick-up Type

- Bring fixture's connection/position to working model (impression taking is based on fixture information)
- Impression taking is relatively complicated but accuracy is better than transfer type
- Impression coping moves as one body with impression body
- Open tray (custom / individual tray) used

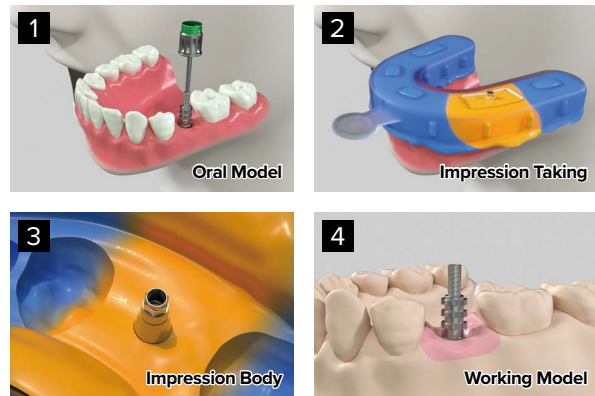

Fixture Level Impression Transfer Type

- Bring fixture's connection/position to working model (impression taking is based on fixture information)
- Convenient in posterior area with limited mouth opening
- Impression coping moves separately from impression body
- Close tray (ready made / stock tray) used

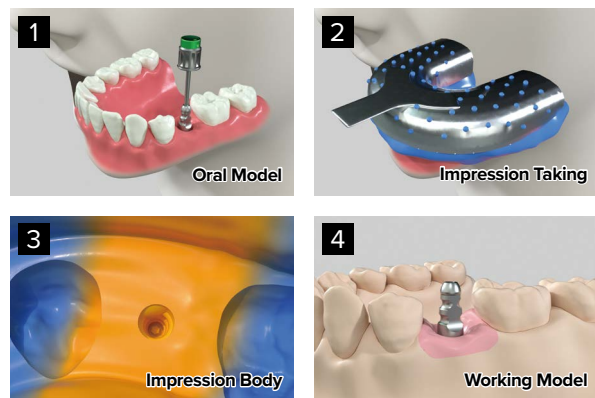







Tightening Torque





Recommended to use the tightening torque below

(Need regular maintenance for the abrasion, damage and functionality of components such as driver, torque wrench etc)



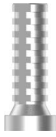





5 ~ 8Ncm

| | | | | |
|---|---|---|---|---|
|  |  | | | |
| Cover Screw | Healing Abutment | | | |
|  |  |  |  |  |
| Pick-Up Impression Coping | Transfer Impression Coping | Multi Pick-Up Impression Coping | Multi Transfer Impression Coping | Multi Healing Cap |

20Ncm

| | | | | |
|---|---|---|---|---|
|  |  |  |  |  |
| Temporary Abutment | Multi Temporary Cylinder | Multi CCM Cast Cylinder | Multi Plastic Cast Cylinder | Multi Ti Link Cylinder |

30Ncm

| | | | | |
|---|---|---|---|---|
|  |  |  |  | |
| Cemented Abutment | Angled Abutment | FreeMilling Abutment | CCM Cast Abutment | |
|  |  |  |  |  |
| Multi Straight Abutment | Multi Angled Abutment | Ball Abutment | Ti Link Abutment | Ti Blank Abutment |

Prosthetic Guide

Abutment Specification Selection

Consideration
Fixture Angle (path) / single, bridge selection

Select Option
Hex / non-hex

Consideration
Fixture platform

Select Option
X-Narrow / Narrow / Mini / Regular / Wide

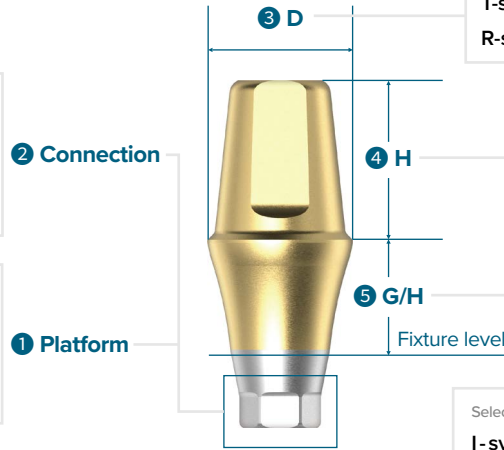

Consideration
Space between adjacent teeth, Diameter of cervical area (Mesio-Distal, Bucco-lingual)

Select Option
I-system Ø4.0 / 4.5 / 5.2 / 5.7 / 6.5
T-system Ø4.0 / 4.5 / 5.0 / 6.0 / 7.0
R-system Ø4.0 / 5.0 / 6.0 / 7.0

Consideration
Height of adjacent teeth, Distance to occlusal teeth

Select Option
I-system 4.0 / 5.5 / 7.0mm
T-system 4.0 / 5.5 / 7.0mm
R-system 5.5 / 7.0mm

Consideration
Fixture Depth / margin position

Select Option
I-system 1.0 / 2.0 / 3.0 / 4.0 / 5.0 / 6.0 / 7.0mm
T-system 1.0 / 2.0 / 3.0 / 4.0 / 5.0 / 6.0 / 7.0mm
R-system 2.0 / 3.0 / 4.0 / 5.0mm

Guide Tip.

Emergence Profile Formation Tip

- Pre surgery planning is important since fixture depth decides abutment's G/H and H
- It is important to select abutment diameter similar to natural tooth's cervical area

Abutment Diameter Selection

● Diameter in cervical area
● Abutment Diameter



※ Natural teeth cervical area mesial-distal / buccal-lingual:
Based on smaller specification among standard specification

- When appropriate abutment specification for restoration was not selected impossible to create natural prosthesis contour like beside

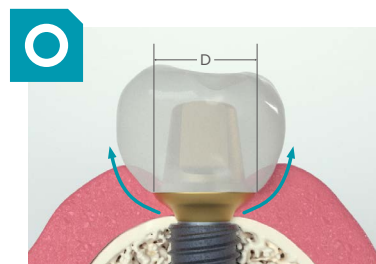

ZENEX System Fixture

D Ø4.5 / L 11.5mm

Cemented Abutment

D Ø6.5 / P/H 5.5mm / G/H 2.0mm

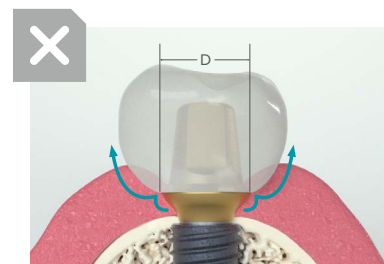

ZENEX System Fixture

D Ø4.5 / L 11.5mm

Cemented Abutment

D Ø5.7 / P/H 5.5mm / G/H 2.0mm

Component & Instrument

Prosthetic KIT

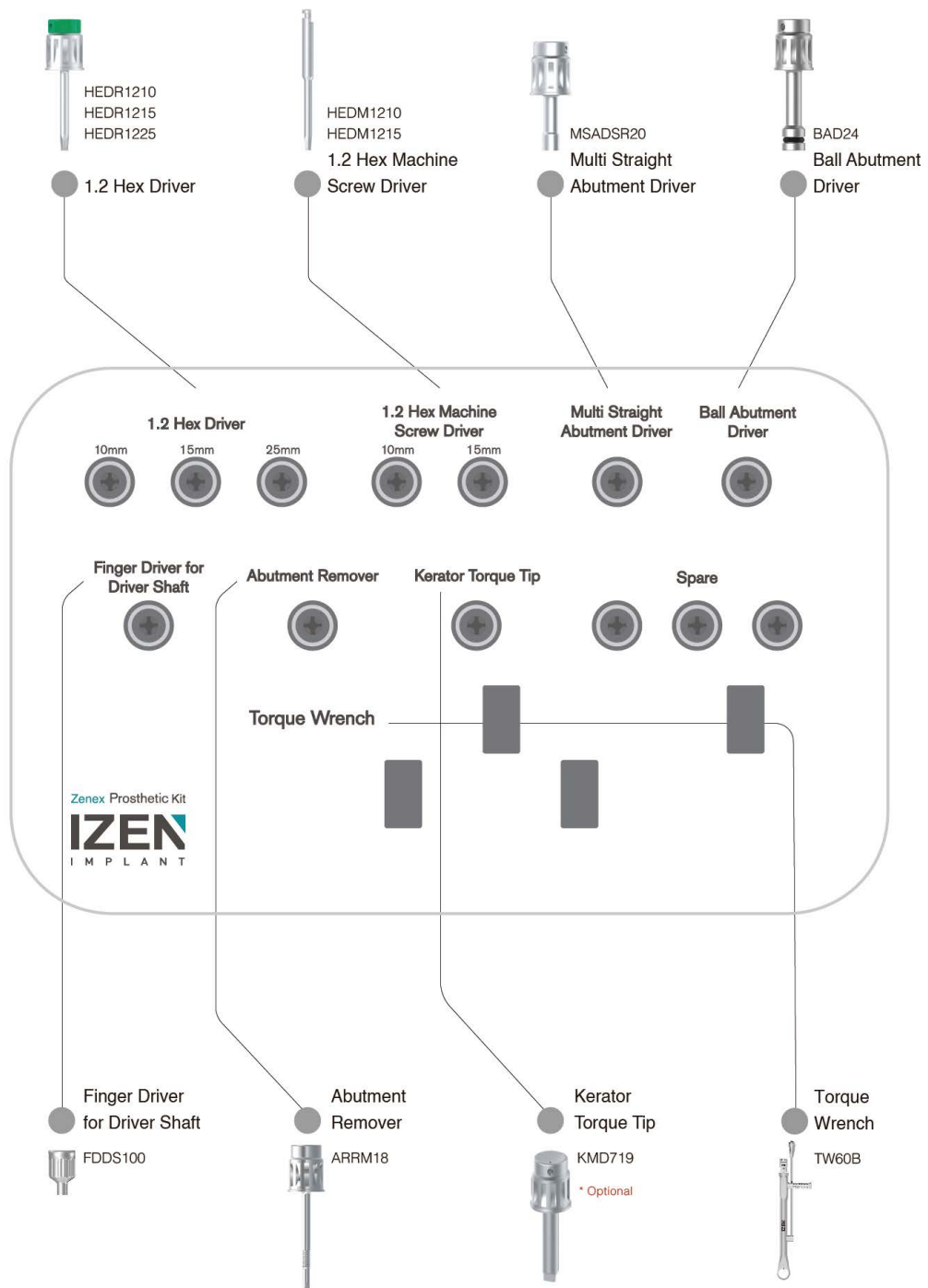

Torque Wrench

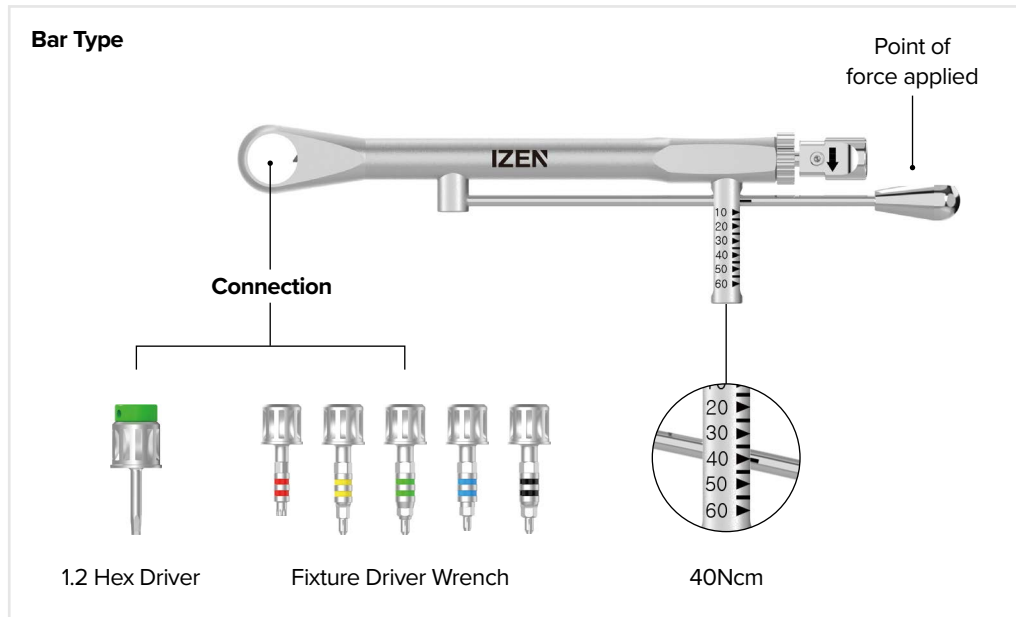

Driver

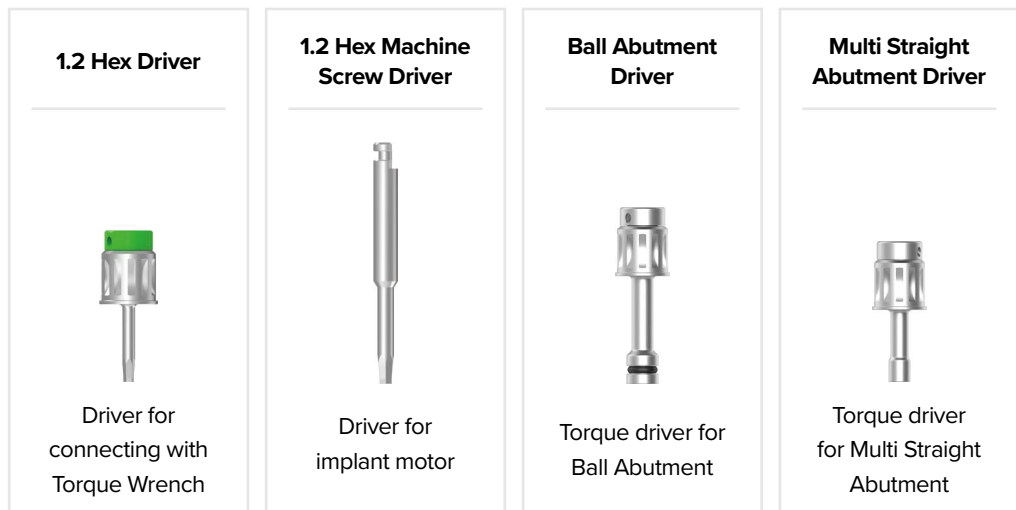

※ Normally, perform rough connection by hand first and tighten in final torque with torque wrench

Right Connection Checking Guide

Cover Screw

- Misconnection happens by the bone near fixture or adjacent tissue and foreign substance
- Check right connection after removing interfering area with bone profiler

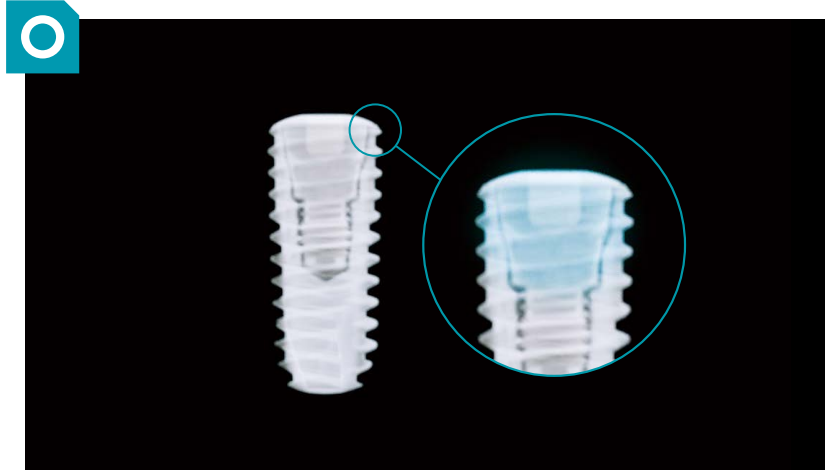

Connection Checkpoint according Fixture Platform



ZENEX PLUS Fixture (X-Narrow)
D Ø3.0 / L 11.5mm

Cover Screw
D Ø2.6 / H 0.4mm

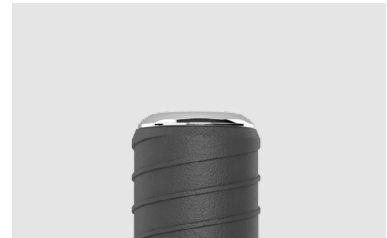

ZENEX MULTI Fixture (Narrow)
D Ø3.0 / L 11.5mm

Cover Screw
D Ø2.9 / H 0.4mm

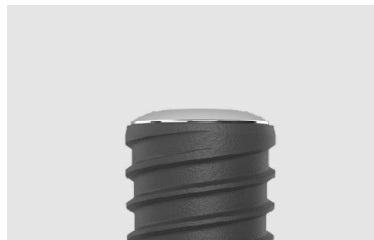

ZENEX MULTI/PLUS Fixture (Mini)
D Ø3.5 / L 11.5mm

Cover Screw
D Ø3.45 / H 0.4mm



ZENEX MULTI/PLUS Fixture (Regular/Wide)
D Ø5.0 / L 11.5mm

Cover Screw
D Ø5.5 / H 0.4mm

Healing Abutment

- If healing abutment and fixture has right connection, there is sealing on the top of taper area inside
- Misconnection happens by the bone near fixture or adjacent tissue and foreign substance
- Fixture failure can happen with plaque and bacteria proliferation in gap
- Check right connection after removing interfering area with bone profiler



Connection Checkpoint according Fixture Platform

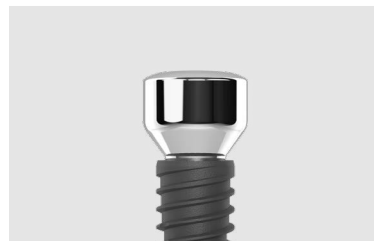

ZENEX PLUS Fixture (X-Narrow)
D Ø3.0 / L 11.5mm

Healing Abutment
D Ø4.0 / H 4.0mm



ZENEX MULTI Fixture (Narrow)
D Ø3.0 / L 11.5mm

Healing Abutment
D Ø4.3 / H 4.0mm (HATM404)



ZENEX MULTI/PLUS Fixture (Mini)
D Ø3.5 / L 11.5mm

Healing Abutment
D Ø4.3 / H 4.0mm (HASR404)



ZENEX MULTI/PLUS Fixture (Regular/Wide)
D Ø5.0 / L 11.5mm

Healing Abutment
D Ø5.5 / H 4.0mm

Impression Coping

Pick-up Impression Coping

- Misconnection occurs when fixture and hex do not connect accurately, or with interference from bone and tissue around fixture
- Check right connection by checking if coping body notch(A) matches with top of fixture or if there is gap inside the 11° taper area

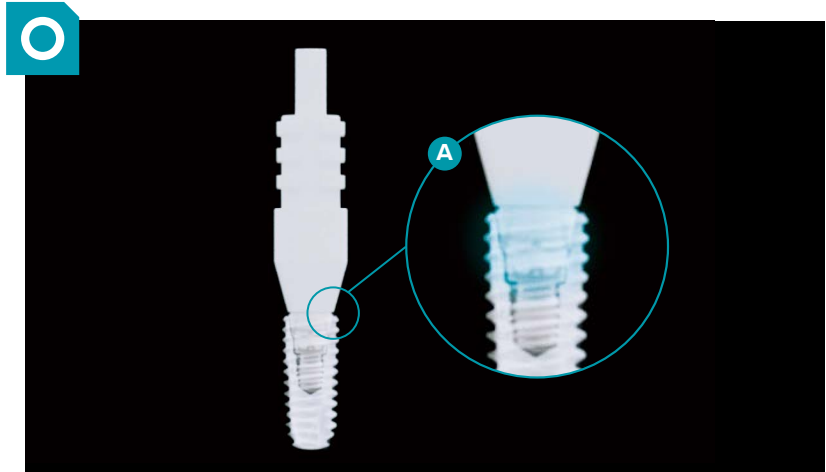

Transfer Impression Coping

- Check right connection by checking if coping body notch(A) matches with top of fixture or if there is gap inside the 11° taper area

※ Transfer impression coping :

Guide pin will not be connected without accurately setting the hex, therefore reduce errors from users

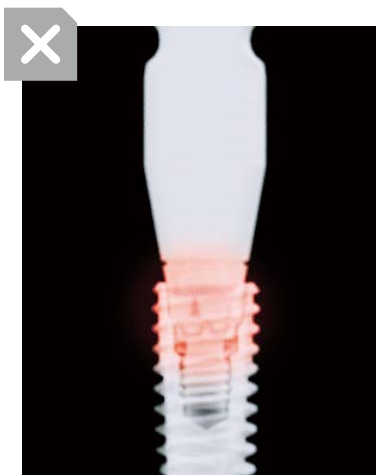

**Connection Checkpoint according
Fixture Platform**

The actual G/H may vary depending on the fixture platform, but all information is already applied to the digital library.

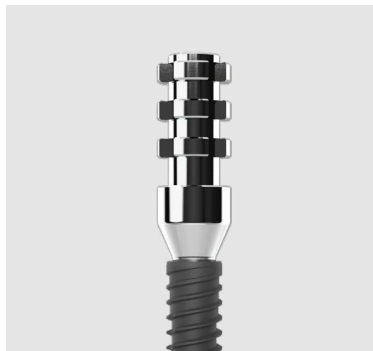

ZENEX PLUS Fixture (X-Narrow)
D Ø3.0 / L 11.5mm

Pick-up Impression Coping
D Ø4.0 / H 11.0mm (PISXH40SS)

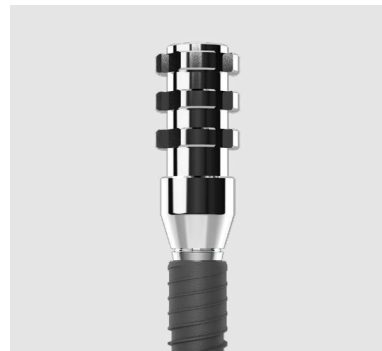

ZENEX MULTI Fixture (Narrow)
D Ø3.0 / L 11.5mm

Pick-up Impression Coping
D Ø4.0 / H 11.0mm (PITMH40SS)



ZENEX MULTI/PLUS Fixture (Mini)
D Ø3.5 / L 11.5mm

Pick-up Impression Coping
D Ø4.0 / H 11.0mm (PISRH40SS)



ZENEX MULTI/PLUS Fixture (Regular/Wide)
D Ø5.0 / L 11.5mm

Pick-up Impression Coping
D Ø6.0 / H 11.0mm (PISRH57SS)

Scanbody

- Misconnection occurs when fixture and hex do not connect accurately, or with interference from bone and tissue around fixture
- Check right connection by checking if Scanbody notch(A) matches with top of fixture or if there is gap inside the 11° taper area
- ZENEX MULTI Fixture X-Narrow does not support digital libraries.

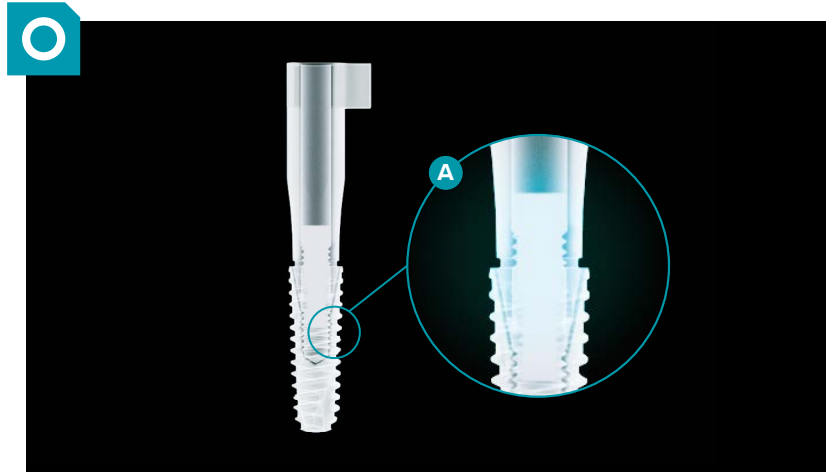

Connection Checkpoint according Fixture Platform

The actual G/H may vary depending on the fixture platform, but all information is already applied to the digital library.



ZENEX MULTI Fixture (Narrow)
D Ø3.0 / L 11.5mm

Scanbody
D Ø4.0 / H 14.0mm (TSBM4014S)



ZENEX MULTI/PLUS Fixture (Mini)
D Ø3.5 / L 11.5mm

Scanbody
D Ø4.0 / H 14.0mm (ISBM4014S)

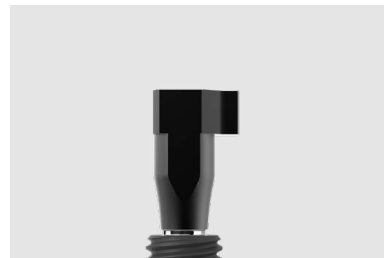

ZENEX MULTI/PLUS Fixture (Regular/Wide)
D Ø5.0 / L 11.5mm

Scanbody
D Ø4.3 / H 10.0mm (ISBR4310S)

Abutment

- Misconnection occurs when fixture and hex do not connect accurately, or with interference from bone and tissue around fixture
- Modify wrong hex setting with x-ray or use Bone profiler to remove interfering area and check right connection

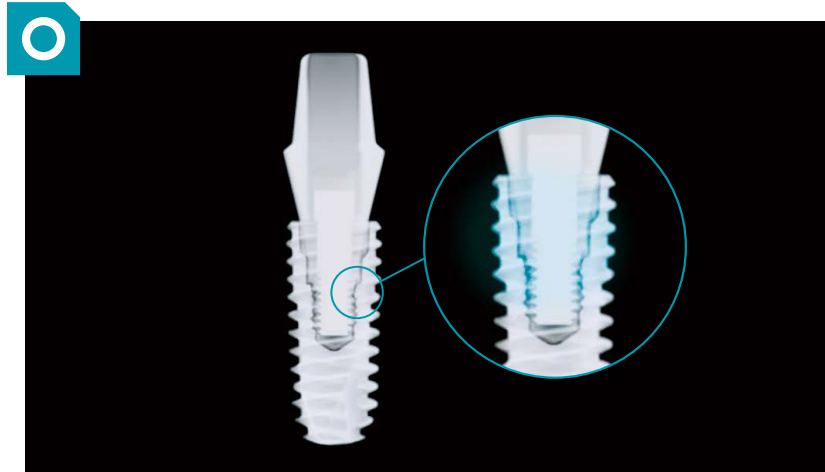
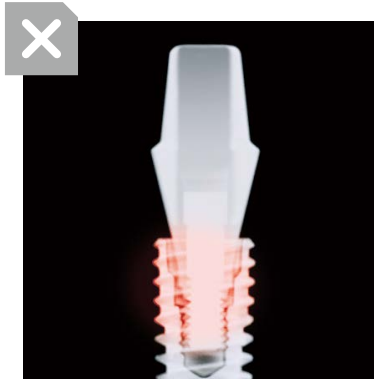

Connection Checkpoint according Fixture Platform

The actual G/H may vary depending on the fixture platform, but all information is already applied to the digital library.

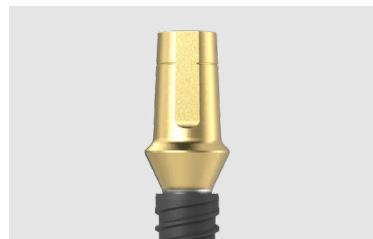

ZENEX PLUS Fixture (X-Narrow)
D Ø3.0 / L 11.5mm

Cemented Abutment
D Ø4.0 / P/H 5.5mm / G/H 2.0mm

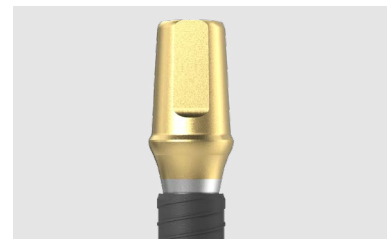

ZENEX MULTI Fixture (Narrow)
D Ø3.0 / L 11.5mm

Cemented Abutment
D Ø4.0 / P/H 5.5mm / G/H 2.0mm
(CATMH40205S)

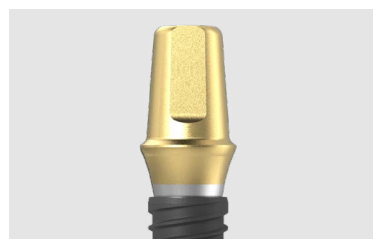

ZENEX MULTI/PLUS Fixture (Mini)
D Ø3.5 / L 11.5mm

Cemented Abutment
D Ø4.5 / P/H 5.5mm / G/H 2.0mm
(CASRH45205S)



ZENEX MULTI/PLUS Fixture (Regular/Wide)
D Ø5.0 / L 11.5mm

Cemented Abutment
D Ø6.5 / P/H 5.5mm / G/H 2.0mm

Prosthetic Fastening Description

Narrow

In the MULTI Fixture narrow, the Gingiva Height increases by 0.5mm compared to the dimensions in the catalog.

(Healing Abutment increases the height)

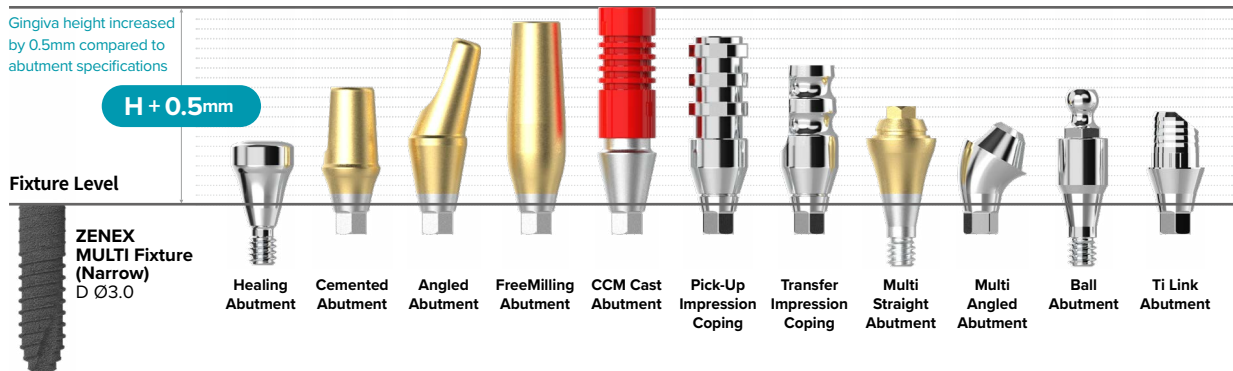

Mini

In the I-System Mini Fixture, the height increases by 0.4mm compared to the product specification when the abutment is fastened.

(The actual increased position is the Gingiva Height, and the Healing Abutment is the Height)

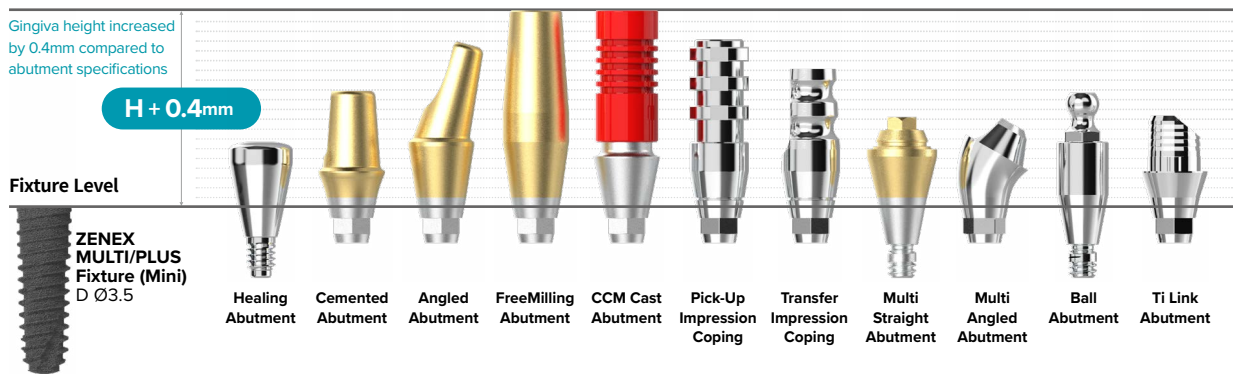

Prosthetic Connection Chart by Diameter

Fixture Platform



| Prosthetics | Fixture | | | |
|--|------------------|----------------|--------------|--------------------------|
| | Ø3.0 X-Narrow | Ø3.0 Narrow | Ø3.5 Mini | Ø4.0~7.0 Regular/Wide |
| Cover Screw | X-N | N | M M M/R/W | R/W R/W M/R/W |
| Healing Abutment | X-N | M | M M M/R/W | R/W R/W M/R/W |
| Abutment Cemented Abutment Angled Abutment FreeMilling Abutment CCM Cast Abutment Multi Abutment Ball Abutment Ti Link Abutment Ti Blank Abutment | X-N | M | M M M/R/W | R/W R/W M/R/W |
| Scanbody | | M | M M M/R/W | R/W R/W M/R/W |
| Impression Coping | X-N | M | M M M/R/W | R/W R/W M/R/W |

ZENEX MULTI/PLUS Fixture Driver Instructions

MULTI



PLUS

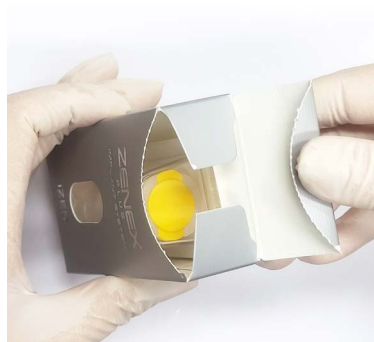

Open the box by pressing the arrow on the front of the Carton Box with your thumb.



Hold the Tyvek paper with one hand and slowly remove it from the Blister.

Remove the Ampule Body by turning the Ampule Cap counterclockwise.

The product remains on the Ampule Cap side.

ZENEX MULTI Fixture Driver Instructions



1 Break down the Ampule Cap from the Inbody Holder



2 Slightly hold the Inbody Holder in order to prevent dropping of the implant.



3 After connecting the driver to the fixture, make sure they are properly connected. Check if the connection is firm by moving sideways.

4

I-System

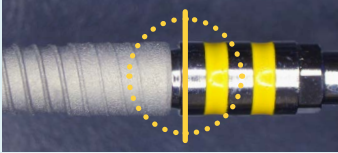

Narrow

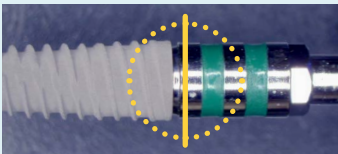

Mini

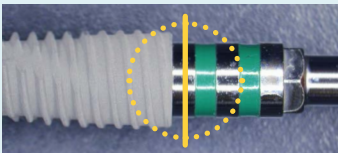

Regular/Wide

T-System

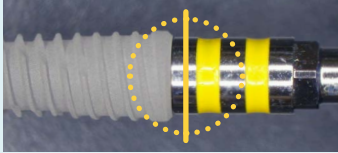

Mini

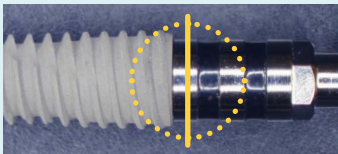

Regular/Wide

R-System

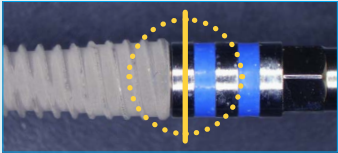

Mini/Regular/Wide

Refer above for different connection levels for each fixtures.

- * I-System Narrow Fixtures are connected 0.5mm higher.
- * I-System Mini Fixtures are connected 0.4mm higher.



5 Once the fixture is properly connected, remove the Inbody Holder without touching the fixture.

ZENEX PLUS Fixture Driver Instructions



1 Break down the Ampule Cap from the Inbody Holder



2 Slightly hold the Inbody Holder in order to prevent dropping of the implant.



3 After connecting the driver to the fixture, make sure they are properly connected. Check if the connection is firm by moving sideways.

4

I-System



X-Narrow



Mini



Regular/Wide

T-System



Mini



Regular/Wide

R-System

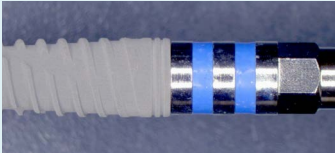

Mini/Regular/Wide

Refer above for different connection levels for each fixtures.

- * I-System X-Narrow Fixtures are connected 0.5mm higher.
- * I-System Mini Fixtures are connected 0.4mm higher.



5 Once the fixture is properly connected, remove the Inbody Holder without touching the fixture.

Prosthetic Flow Chart

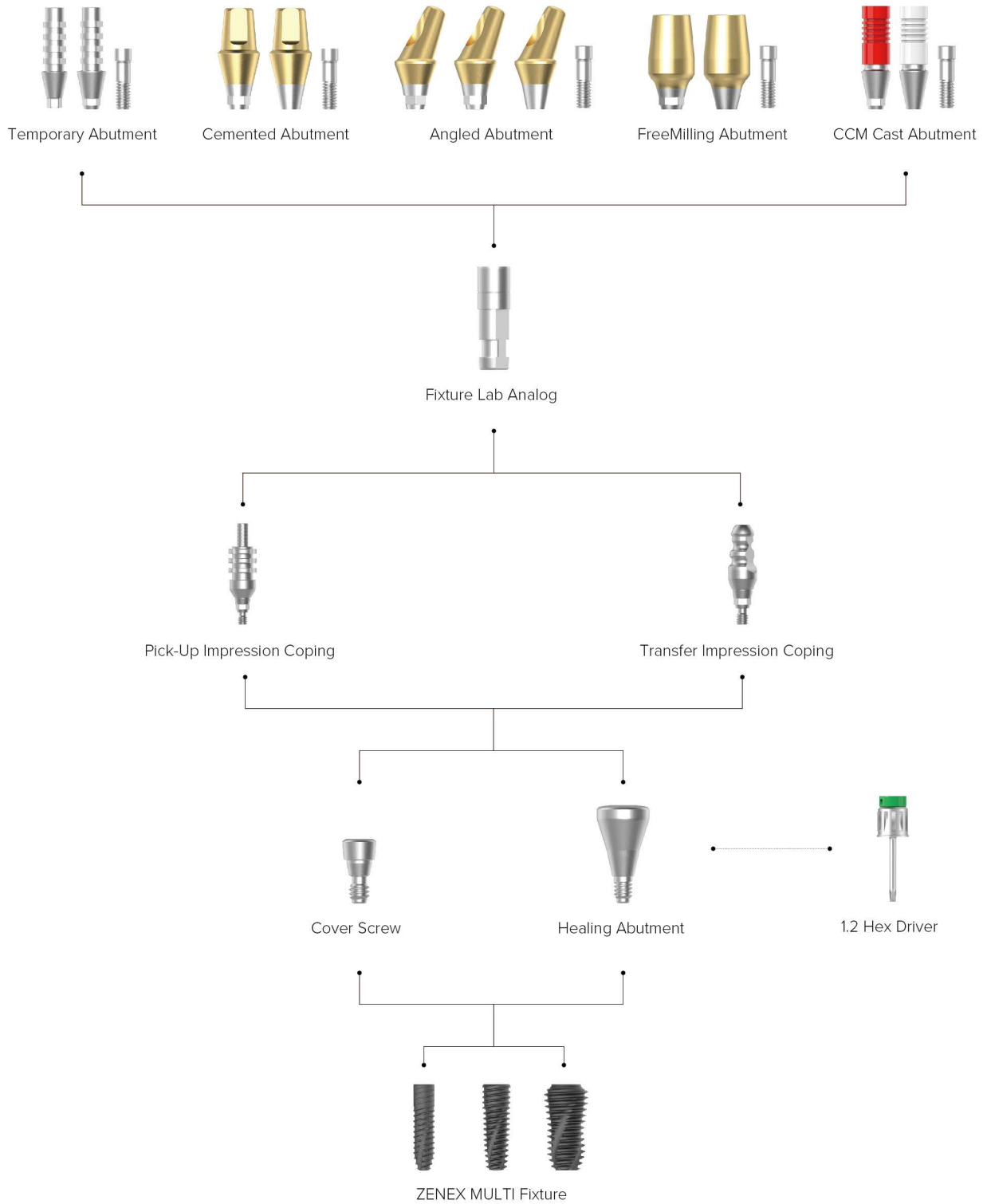

CEMENTED ABUTMENT

Prosthetic Process

- 31 **Step 1** Separation of Cover Screw or Healing Abutment
- 32 **Step 2** Connect the Impression Coping
- 34 **Step 3** Impression Taking & Connect the Lab Analog
- 36 **Step 4** Working Model Production
- 37 **Step 5** Wax-Up, Casting & Porcelain Build-Up
- 38 **Step 6** Transfer Jig Production
- 39 **Step 7** Fastening of intraoral Abutment & installation of prosthesis



Cemented Abutment



Abutment Features

The top part of the post is rounded, making it easy to fasten the zirconia crown.



Abutment for manufacturing Cement/Combination-retained type prosthesis

Select specification fits for fixture connection.

Customized by grinding

(need to be maintained at least 3.0mm of Abutment Length above Fixture Platform)

Fixture Level Impression

Tighten with 1.2 Hex Driver

Recommended tightening torque

X-Narrow: 20Ncm

Narrow, Mini, Regular, Wide: 30Ncm

Abutment Diameter Selection

- Ø4.0
- Ø4.5
- Ø5.2
- Ø5.7
- Ø6.5



Fixture Level Impression

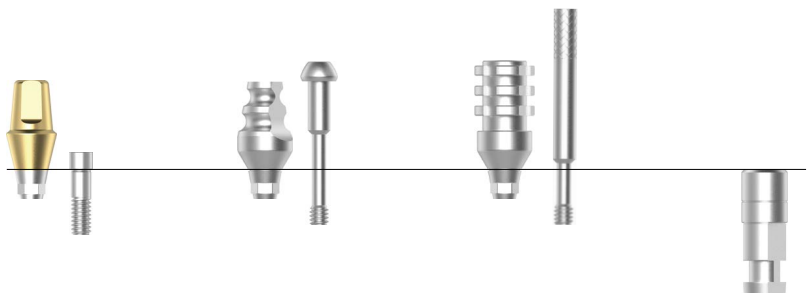

Step 1



Separation of Cover Screw or Healing Abutment

Remove Cover Screw or Healing Abutment with 1.2 Hex Driver. At this time, connect dental floss to the spinner in the handle part of the Driver so that the Driver does not pass to the patient's neck. And prepare Impression Coping for the connection of the Fixture.

Healing Abutment



Cover Screw



Chair Side Step 1

Removal of Cover Screw or Healing Abutment

NOTE: Connect dental floss to the spinner in the handle part of the Driver so that the Driver does not pass to the patient's neck.

Step 2



Connect the Impression Coping

Transfer Impression Coping

Using 1.2 Hex Driver, connect the Transfer Impression Coping that matches the Fixture with the inside of the Fixture, and connect the Guide Pin.

1.2 Hex Driver



Transfer Impression Coping



Check the exact contact between the Impression Coping and the Fixture with X-ray.



1.2 Hex Driver



Pick-up Impression Coping



Pick-up Impression Coping

Using 1.2 Hex Driver, connect Pick-up Impression Coping that matches the Fixture with the inside of the Fixture and connect the Guide Pin.



Check the exact contact between the Impression Coping and the Fixture with X-ray.



Chair Side Step 2

Connect the Impression Coping

- Select the appropriate type of Impression Coping that matched the Fixture with the inside of the Fixture
- Using 1.2 Hex Driver, connect the Impression Coping and connect the Guide Pin
- Check the exact contact between the Impression Coping and the Fixture with X-ray.

Step 3



Impression Taking & Connect the Lab Analog

Transfer Impression Coping

After injecting the impression material using an Injection syringe around the Coping, the tray filled with the impression material is placed in the oral cavity to obtain an accurate impression.

After removing blood marks and other residues deposited in the impression body, separate the intraoral Transfer Impression Coping and connect it to the Lab Analog.

After contacting the connected Coping and Analog with the Transfer Impression Coping in the impression body, confirm the cross section accurately and deliver it to the Lab.

Transfer Impression Coping

Lab Analog

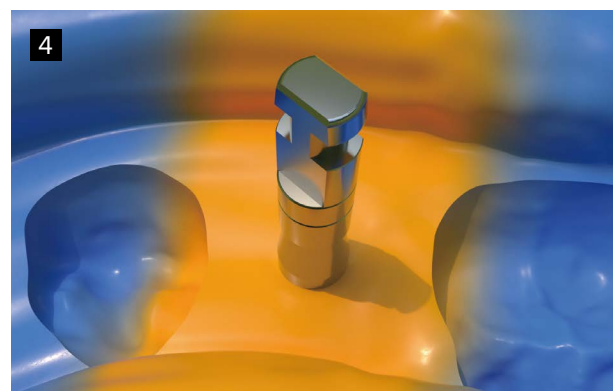
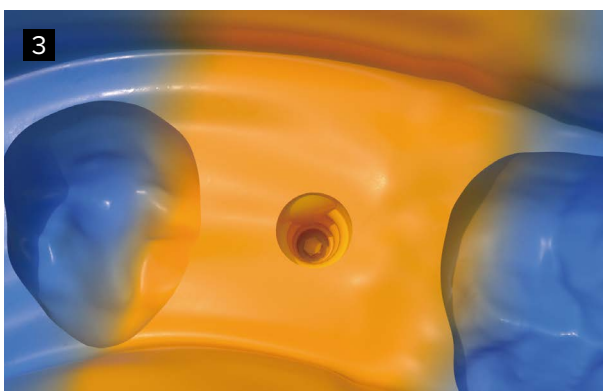
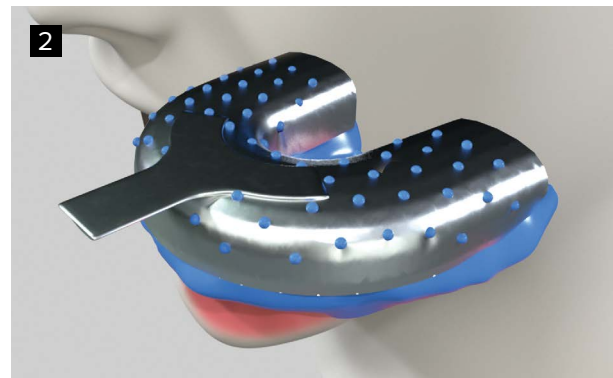
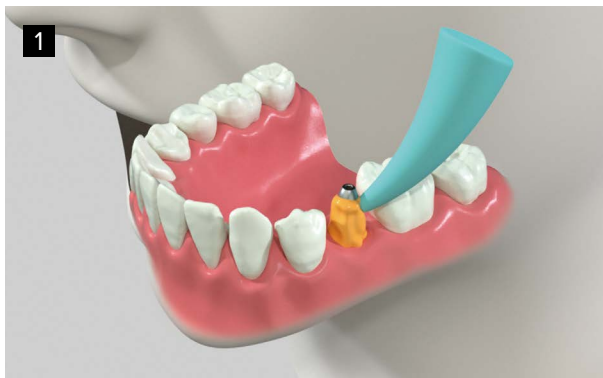
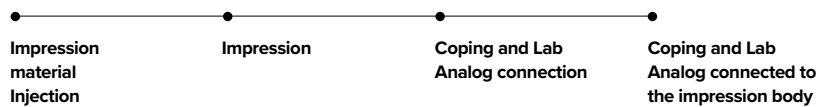

Pick-up Impression Coping



Lab Analog



Pick-up Impression Coping

After forming a suitable hole so that the head of the Guide Pin can be exposed outside the prepared individual tray, try the tray first to see if the head of the Guide Pin is visible through the hole.

Rubber impression material is injected without gap around Pick-up Impression Coping, and impression is obtained by accurately positioning the tray coated with the impression material.

After the impression material is hardened, unfasten the Guide Pin to remove the tray from the oral cavity, check for abnormalities in the impression body, remove bloodstains and other residues, and then deliver it to the lab.

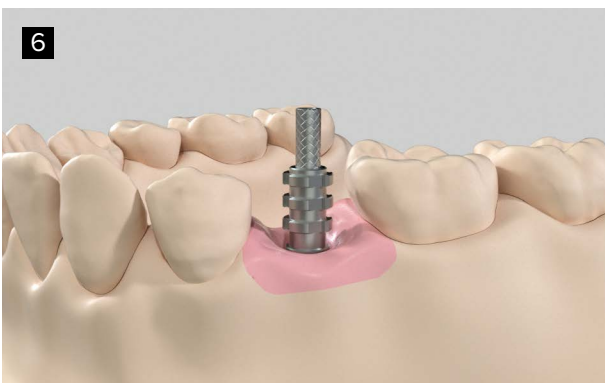
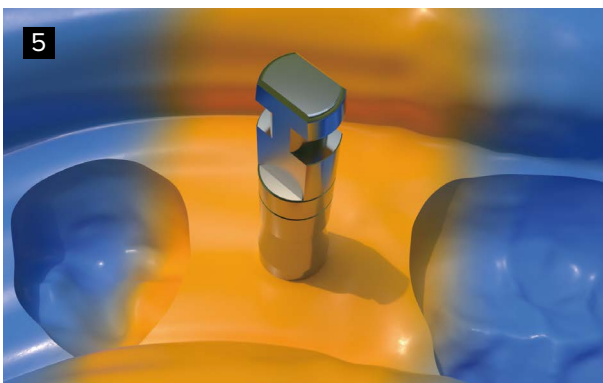
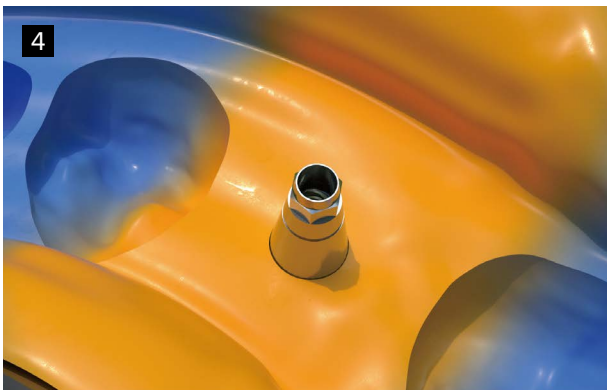
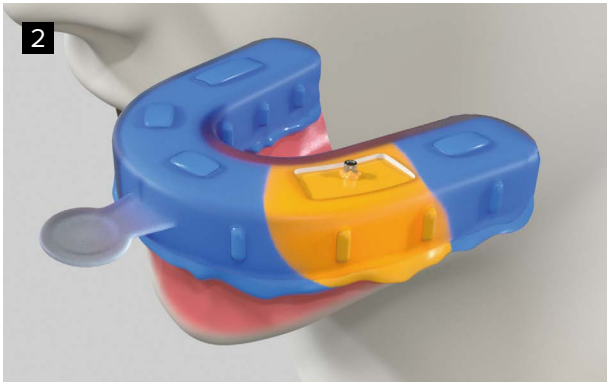

Lab Side

Step 4

Working Model
Production

After passing the body making impressions in the doctor's office after checking the correct fastening of the Lab Analog form an Artificial Gum around Analog, and injecting the anhydrite is produced by the Working Model.

Accurately fasten the Cemented Abutment that matches the Analog on the work model.

Cemented Abutment



Step 5

Wax-Up, Casting & Porcelain Build-Up

Use Pattern Resin to make Resin Cap, and after Wax-Up, make PFM prosthesis in the usual way.

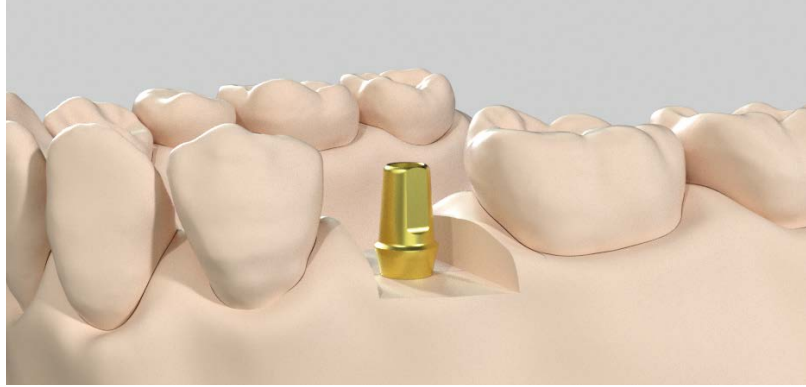

Lab Side

Step 6 (optional)

Transfer Jig Production

Remove Artificial Gum from the working model and connect the Abutment accurately using 1.2 Hex Driver. Next, build the Pattern Resin to make the Transfer Jig.

When making a prosthesis by directly fastening the Abutment on the model, it is necessary to make a Transfer Jig to reproduce the position of the Abutment on the model as it is in the oral cavity.

In particular, in the case of using a non-hex type Abutment, there is no repositioning function, so it is necessary to make an accurate Transfer Jig using pattern resin when receiving regardless of single/bridge.



Step 7



Fastening of intraoral Abutment & installation of prosthesis

Using a Transfer Jig, place the Abutment into the oral cavity accurately and fasten the Abutment with a 1.2 Hex Driver.

The correct connection between the Abutment and the Fixture is confirmed by X-ray.

The final tightening is to 30Ncm (to be tightened according to the recommended tightening torque value guided by Abutment) using a 1.2 Hex Driver and a Torque Wrench.

After checking the passive fit of the prosthesis margin, proper contact with the adjacent teeth, and occlusion with the antagonist teeth, block-out the screw hole and cement the final prosthesis on the Abutment.

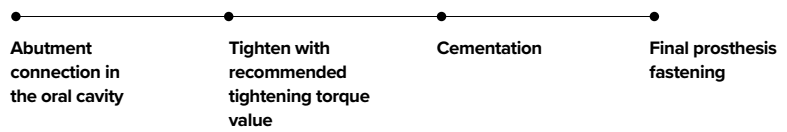

1.2 Hex Driver



Torque Wrench



Cemented Abutment



ANGLED ABUTMENT

Prosthetic Process

- 43 Step 1** Separation of Cover Screw or Healing Abutment
- 43 Step 2** Connect the Impression Coping
- 44 Step 3** Impression Taking & Connect the Lab Analog
- 45 Step 4** Working Model Production
- 45 Step 5** Wax-Up, Casting & Porcelain Build-Up
- 46 Step 6** Transfer Jig Production
- 47 Step 7** Fastening of Abutment in oral cavity & installation of prosthesis



Angled Abutment

X-Narrow

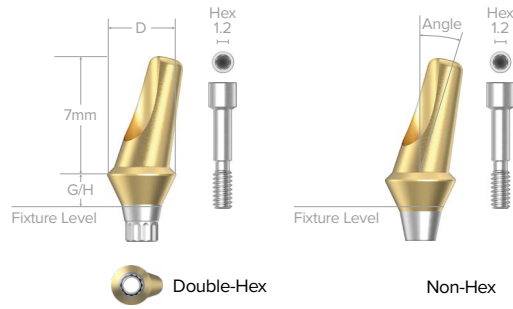

Narrow

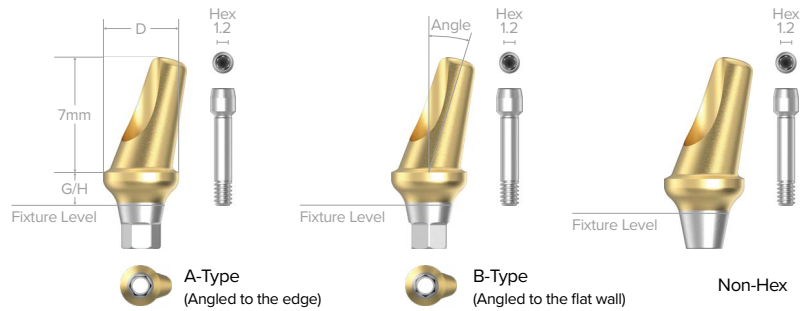

Mini, Regular & Wide

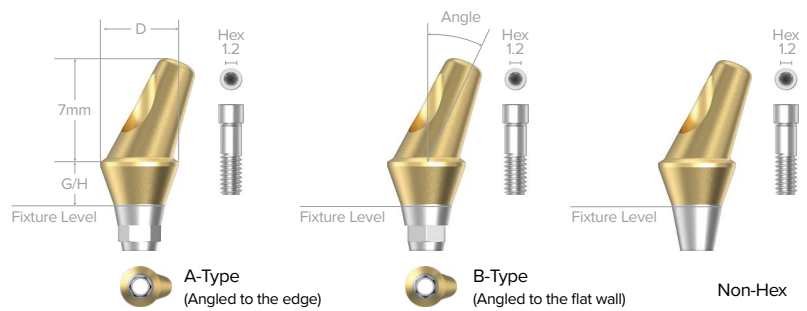

Abutment Features

The top part of the post is rounded, making it easy to fasten the zirconia crown.



Abutment for manufacturing Cement/Combination-retained type prosthesis

Various types of Angle

- 15° for Ø3.0 X-Narrow Fixture
- 17° for Ø3.0 Narrow Fixture
- 15° & 25° for Mini, Regular and Wide Fixture [Ø3.5 ~ Ø7.0]

Select specification fits for fixture connection.

Fixture Level Impression

Can be positioned in 12 directions by selecting A or B type

Tighten with 1.2 Hex Driver

Recommended tightening torque

X-Narrow: 20Ncm

Narrow, Mini, Regular, Wide: 30Ncm

Step 1



Separation of Cover Screw or Healing Abutment

Remove Cover Screw or Healing Abutment with 1.2 Hex Driver. At this time, connect dental floss to the spinner in the handle part of the Driver so that the Driver does not pass to the patient's neck. And prepare Impression Coping for the connection of the Fixture.

Healing Abutment



Cover Screw



Step 2



Connect the Impression Coping

Transfer Impression Coping

Using 1.2 Hex Driver, connect the Transfer Impression Coping that matches the Fixture with the inside of the Fixture, and connect the Guide Pin.

1.2 Hex Driver



Transfer Impression Coping



Check the exact contact between the impression Coping and the Fixture with X-ray.



Step 3



Impression Taking & Connect the Lab Analog

Lab Analog



Transfer Impression Coping

After injecting the impression material using an Injection syringe around the Coping, the tray filled with the impression material is placed in the oral cavity to obtain an accurate impression.

After removing blood marks and other residues deposited in the impression body, separate the intraoral Transfer Impression Coping and connect it to the Lab Analog.

After contacting the connected Coping and Analog with the Transfer Impression Coping in the impression body, confirm the cross section accurately and deliver it to the Lab.

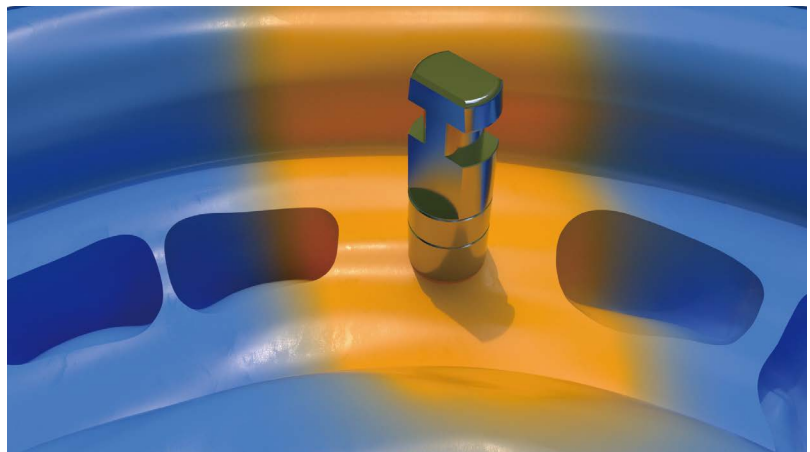
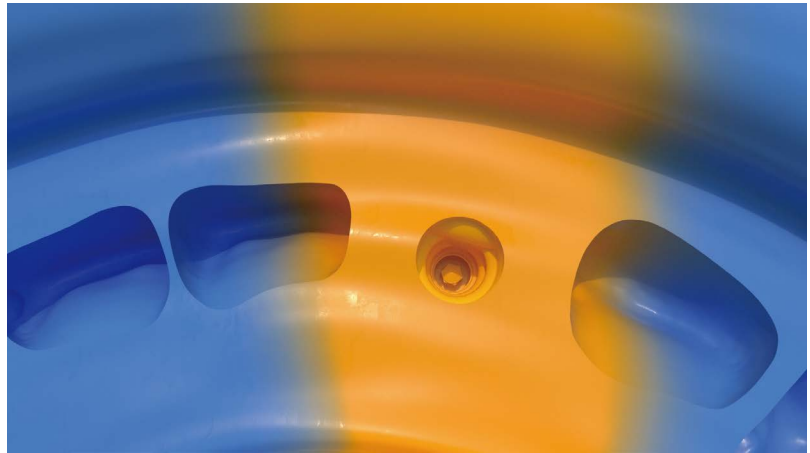
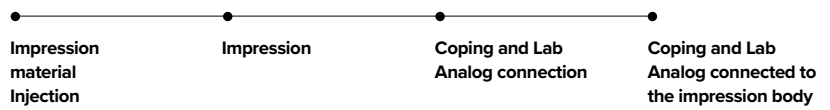

Step 4

Working Model Production

After passing the body making impressions in the doctor's office after checking the correct fastening of the Lab Analog form an Artificial Gum around Analog, and injecting the anhydrite is produced by the Working Model.

Accurately fasten the Angled Abutment that matches the Analog on the work model.

Angled Abutment



Step 5

Wax-Up, Casting & Porcelain Build-Up

Use Pattern Resin to make Resin Cap, and after Wax-Up, make PFM prosthesis in the usual way.



Lab Side

Step 6 (optional)

Transfer Jig Production

Remove Artificial Gum from the working model and connect the Abutment accurately using 1.2 Hex Driver. Next, build the Pattern Resin to make the Transfer Jig.

When making a prosthesis by directly fastening the Abutment on the model, it is necessary to make a Transfer Jig to reproduce the position of the Abutment on the model as it is in the oral cavity.

In particular, in the case of using a non-hex type Abutment, there is no repositioning function, so it is necessary to make an accurate Transfer Jig using pattern resin when receiving regardless of single/bridge.

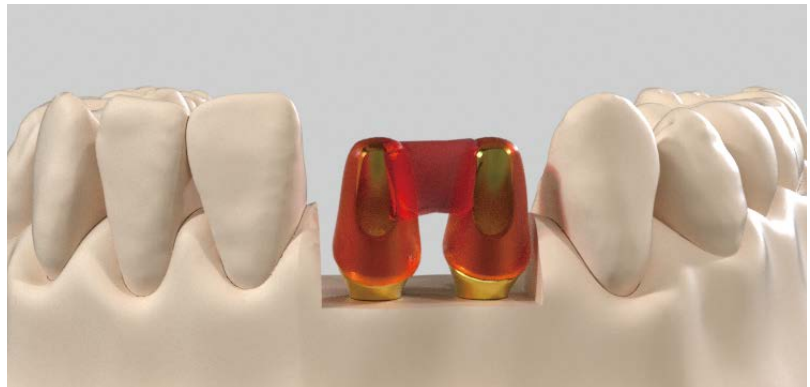
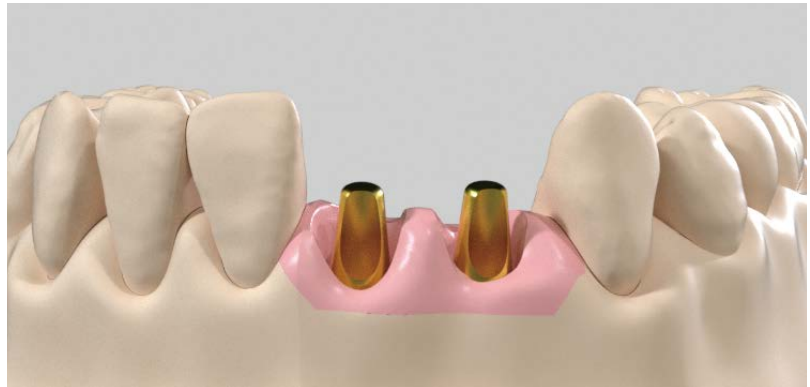

Step 7



Fastening of Abutment in oral cavity & installation of prosthesis

Using a Transfer Jig, place the Abutment into the oral cavity accurately and fasten the Abutment with a 1.2 Hex Driver.

The correct connection between the Abutment and the Fixture is confirmed by X-ray.

The final tightening is tightened to 30Ncm (to be tightened according to the recommended tightening torque value guided by Abutment) using a 1.2 Hex Driver and a Torque Wrench.

After checking the passive fit of the prosthesis margin, proper contact with the adjacent teeth, and occlusion with the antagonist teeth, block-out the screw hole and cement the final prosthesis on the Abutment.

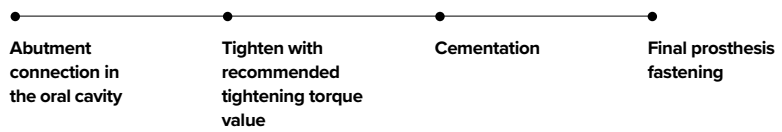

1.2 Hex Driver



Torque Wrench



Angled Abutment



FREEMILLING ABUTMENT

Prosthetic Process

- 51 **Step 1** Separation of Cover Screw or Healing Abutment
- 51 **Step 2** Connect the Impression Coping
- 53 **Step 3** Impression Taking & Connect the Lab Analog
- 55 **Step 4** Working Model Production and Abutment Milling
- 56 **Step 5** Wax-Up, Casting & Porcelain Build-Up
- 57 **Step 6** Transfer Jig Production
- 58 **Step 7** Fastening of Abutment in oral cavity & installation of prosthesis



FreeMilling Abutment



Abutment for manufacturing Cement/Combination-retained type prosthesis

Used when creating free marginal space for Abutment

Select specification fits for fixture Connection

Customized by grinding

(need to be maintained at least 3.0mm of Abutment Length above Fixture Platform)

Fixture Level Impression

Tighten with 1.2 Hex Driver

Recommended tightening torque

X-Narrow: 20Ncm

Narrow, Mini, Regular, Wide: 30Ncm

When using a Narrow Fixture (Ø3.0), use Mini Type FreeMilling Abutment of T-System.

Step 1



Separation of Cover Screw or Healing Abutment

Healing Abutment



Cover Screw



Remove Cover Screw or Healing Abutment with 1.2 Hex Driver. At this time, connect dental floss to the spinner in the handle part of the Driver so that the Driver does not pass to the patient's neck. And prepare Impression Coping for the connection of the Fixture.



Step 2



Connect the Impression Coping

1.2 Hex Driver



Transfer Impression Coping



Transfer Impression Coping

Using 1.2 Hex Driver, connect the Transfer Impression Coping that matches the Fixture with the inside of the Fixture, and connect the Guide Pin.



Check the exact contact between the impression Coping and the Fixture with X-ray.



1.2 Hex Driver



Pick-up Impression Coping



Pick-up Impression Coping

Using 1.2 Hex Driver, connect Pick-up Impression Coping that matches the Fixture with the inside of the Fixture and connect the Guide Pin.



Check the exact contact between the impression Coping and the Fixture with X-ray.



Step 3



Impression Taking & Connect the Lab Analog

Lab Analog



Transfer Impression Coping

After injecting the impression material using an Injection syringe around the Coping, the tray filled with the impression material is placed in the oral cavity to obtain an accurate impression.

After removing blood marks and other residues deposited in the impression body, separate the intraoral Transfer Impression Coping and connect it to the Lab Analog.

After contacting the connected Coping and Analog with the Transfer Impression Coping in the impression body, confirm the cross section accurately and deliver it to the Lab.

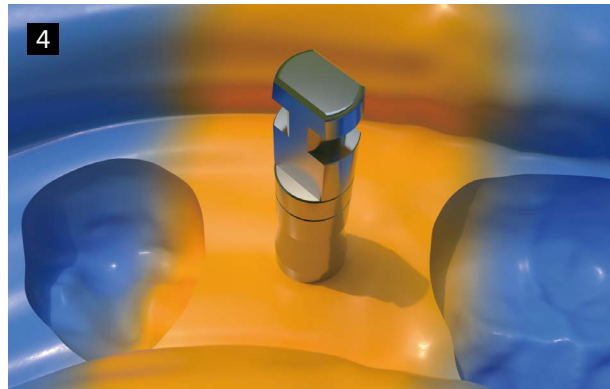
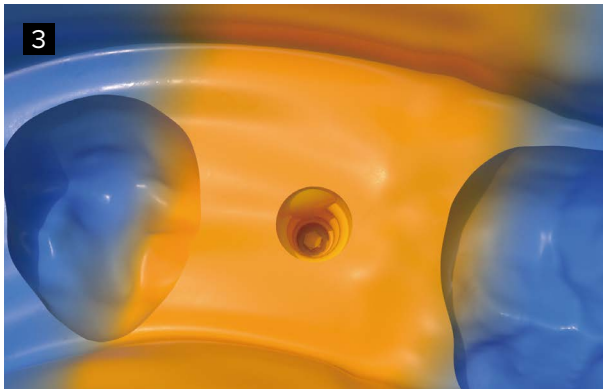
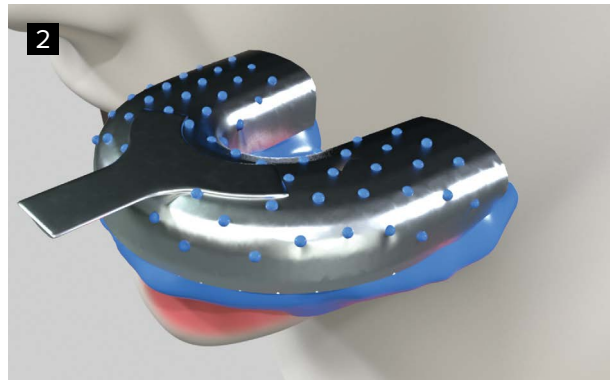
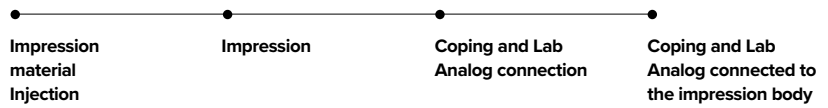

Lab Analog



Pick-up Impression Coping

After forming a suitable hole so that the head of the Guide Pin can be exposed outside the prepared individual tray, try the tray first to see if the head of the Guide Pin is visible through the hole.

Rubber impression material is injected without gap around Pick-up Impression Coping, and impression is obtained by accurately positioning the tray coated with the impression material.

After the impression material is hardened, unfasten the Guide Pin to remove the tray from the oral cavity, check for abnormalities in the impression body, remove bloodstains and other residues, and then deliver it to the lab.

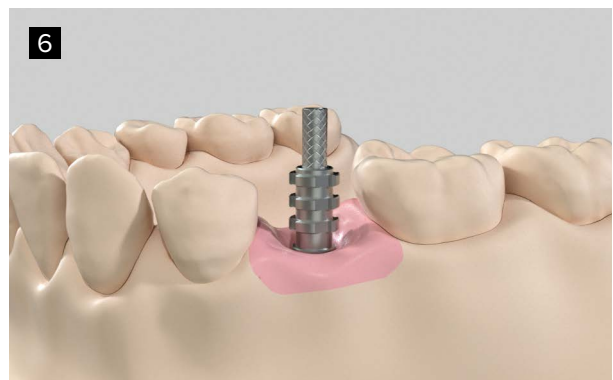
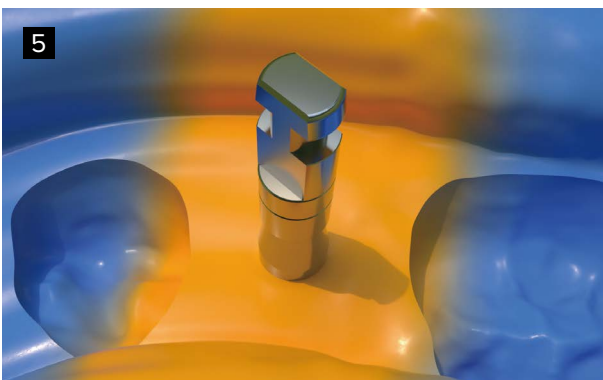
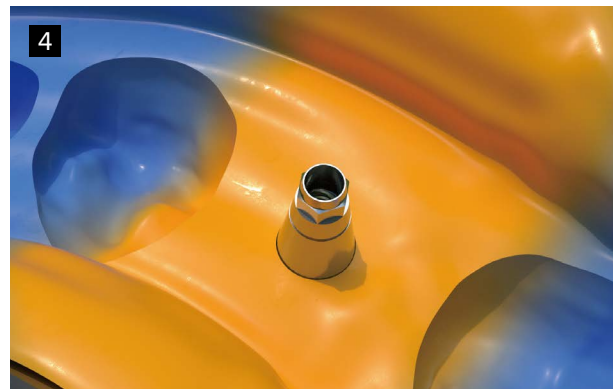
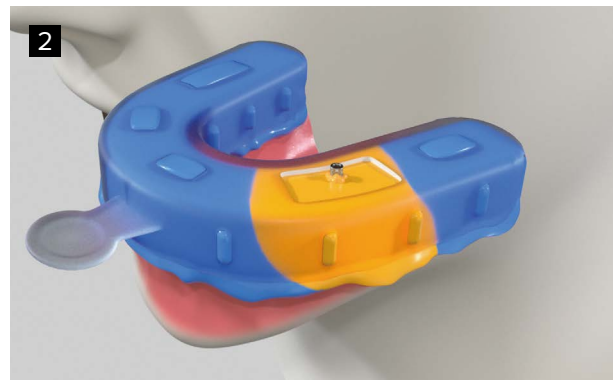

Step 4

**Working Model
Production and
Abutment Milling**

After passing the body making impressions in the doctor's office after checking the correct fastening of the Lab Analog form an Artificial Gum around Analog, and injecting the anhydrite is produced by the Working Model.

Place the FreeMilling Abutment that matches the Analog on the model on the work surface so that it is reproduced as an optimal Custom Abutment, and then mill.

The design parameters for the FreeMilling Abutment

| | |
|---------------------------------|-------------|
| Post Height (min/max) | 4mm/9mm |
| Gingiva Height (min/max) | 2.0mm/4.0mm |
| Angulation | 0° |

The FreeMilling Abutment is to be hand milled only.

FreeMilling Abutment



Lab Side

Step 5

Wax-Up, Casting & Porcelain Build-Up

After milling, make Resin Cap using Pattern Resin, and Wax-Up.

At this time, apply the Rubber Sep that satisfies both the cement space and the separating material role as thin as the color does not reflect on the Abutment surface to make the Resin Cap.

Cap using Rubber Sep is easy to separate, and the space where Rubber Sep is removed has the advantage of compensating for a certain level of metal casting shrinkage.

After Wax-Up, the PFM prosthesis is fabricated in the usual way.

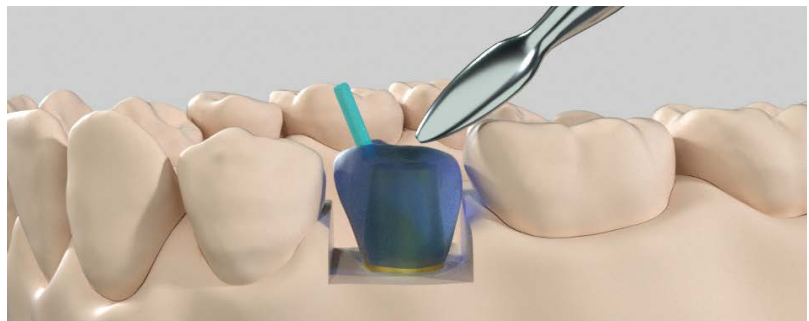
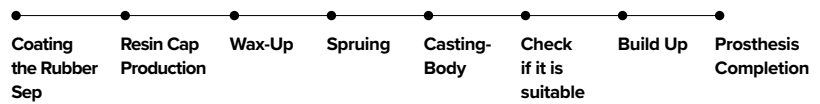

Transfer Jig Production

Remove Artificial Gum from the working model and connect the Abutment accurately using 1.2 Hex Driver. Next, build the Pattern Resin to make the Transfer Jig.

When making a prosthesis by directly fastening the Abutment on the model, it is necessary to make a Transfer Jig to reproduce the position of the Abutment on the model as it is in the oral cavity.

In particular, in the case of using a non-hex type Abutment, there is no repositioning function, so it is necessary to make an accurate Transfer Jig using pattern resin when receiving regardless of single/bridge.



Step 7



Fastening of Abutment in oral cavity & installation of prosthesis

Using a Transfer Jig, place the Abutment into the oral cavity accurately and fasten the Abutment with a 1.2 Hex Driver.

The correct connection between the Abutment and the Fixture is confirmed by X-ray.

The final tightening is 30Ncm (to be tightened according to the recommended tightening torque value guided for each Abutment) using a 1.2 Hex Driver and a Torque Wrench.

After checking the passive fit of the prosthesis margin, proper contact with the adjacent teeth, and occlusion with the antagonist teeth, block-out the screw hole and cement the final prosthesis on the Abutment.

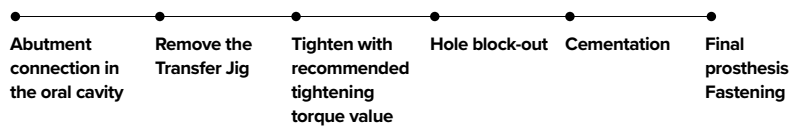

1.2 Hex Driver



Torque Wrench



FreeMilling Abutment



CCM CAST ABUTMENT

Prosthetic Process

- 61 **Step 1** Separation of Cover Screw or Healing Abutment
- 61 **Step 2** Connect the Impression Coping
- 62 **Step 3** Impression Taking
- 63 **Step 4** Fastening of Healing Abutment or Production of Temporary Abutment
- 64 **Step 5** Working Model Production
- 65 **Step 6** Wax-Up
- 66 **Step 7** Casting
- 67 **Step 8** Porcelain build up
- 68 **Step 9** Oxide film removal
- 69 **Step 10** Fastening of intraoral Abutment & installation of prosthesis



CCM Cast Abutment

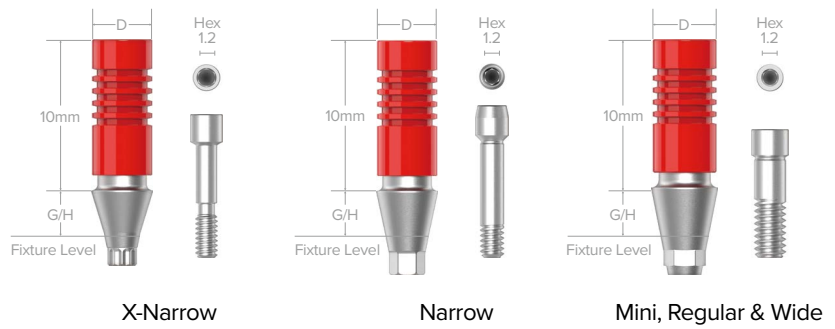

Abutment for manufacturing customized abutment in difficult and complicated cases

Select specification fits for fixture connection

Fixture Level Impression

Casting with non-precious alloy for manufacturing customized prosthesis

Melting point of CCM : **1,400 ~ 1,550°C**

(This is the melting temperature of our CCM Abutment raw material because it can be mistaken for the recommended temperature during casting. The operator must work at a lower temperature than this.)

Tighten with 1.2 Hex Driver

Recommended tightening torque

X-Narrow: 20Ncm

Narrow, Mini, Regular, Wide: 30Ncm

Step 1



Separation of Cover Screw or Healing Abutment

Remove Cover Screw or Healing Abutment with 1.2 Hex Driver. At this time, connect dental floss to the spinner in the handle part of the Driver so that the Driver does not pass to the patient's neck. And prepare Impression Coping for the connection of the Fixture.

Healing Abutment



Cover Screw



Step 2



Connect the Impression Coping

Pick-up Impression Coping

Using 1.2 Hex Driver, connect Pick-up Impression Coping that matches the Fixture with the inside of the Fixture and connect the Guide Pin.

1.2 Hex Driver



Pick-up Impression Coping



Check the exact contact between the impression Coping and the Fixture with X-ray.



Step 3

Impression Taking

Pick-up Impression Coping

After forming a suitable hole so that the head of the Guide Pin can be exposed outside the prepared individual tray, try the tray first to see if the head of the Guide Pin is visible through the hole.

Rubber impression material is injected without gap around Pick-up Impression Coping, and impression is obtained by accurately positioning the tray coated with the impression material.

After the impression material is hardened, unfasten the Guide Pin to remove the tray from the oral cavity, check for abnormalities in the impression body, remove bloodstains and other residues, and then deliver it to the lab.

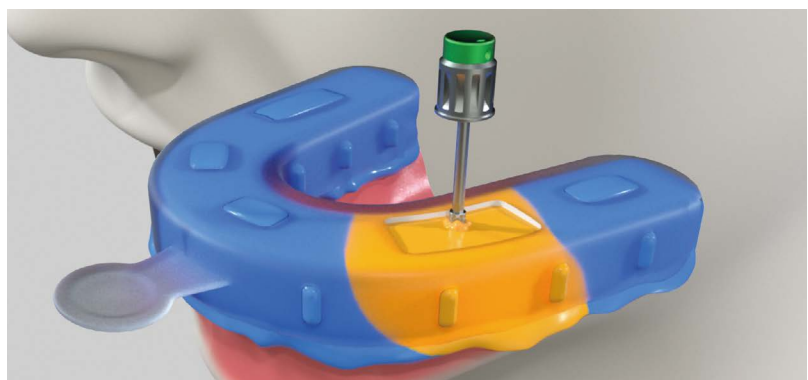

Step 4

Fastening of Healing Abutment or Production of Temporary Abutment

Temporary Abutment



After taking the impression, separate from the Impression Coping oral cavity

Retighten the Healing Abutment to protect the Abutment until the prosthesis is installed

The Temporary Abutment production according to the case



Lab Side

Step 5

Working Model
Production

After passing the body making impressions in the doctor's office after checking the correct fastening of the Lab Analog form an Artificial Gum around Analog, and injecting the anhydrite is produced by the Working Model.

Lab Analog

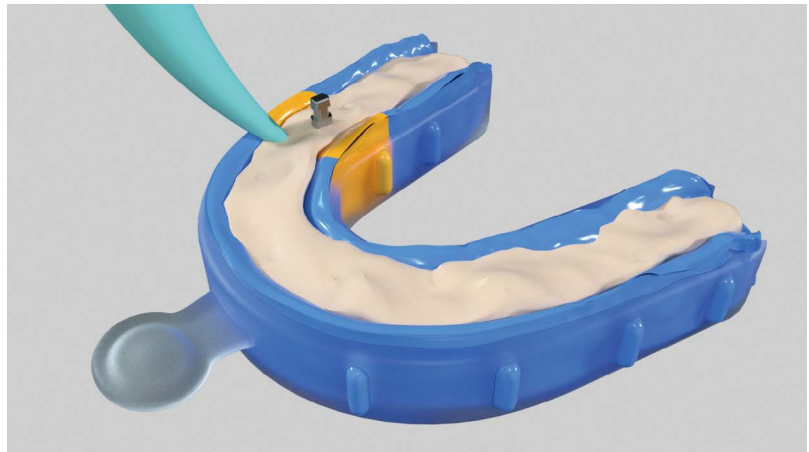
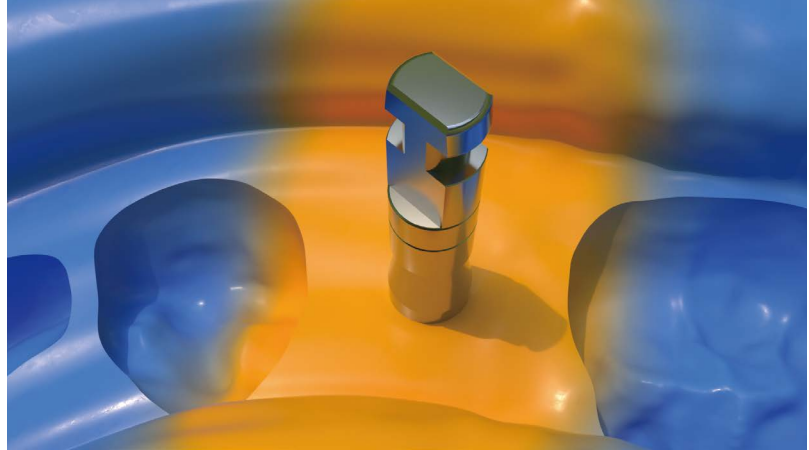

CCM Cast Abutment



Step 6

Wax-Up

Place the CCM Cast Abutment on the model and fasten it with a screw using a 1.2 Hex Driver.

After adjusting the plastic sleeve to an appropriate height, perform wax-up for the substructure of the prosthesis (Casting metal must use CCM).

After forming a screw hole and wax-up, proceed with the usual PFM manufacturing method.

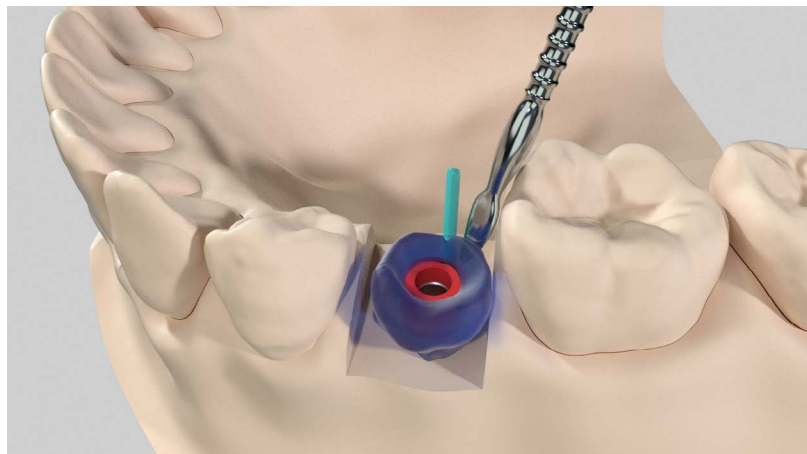
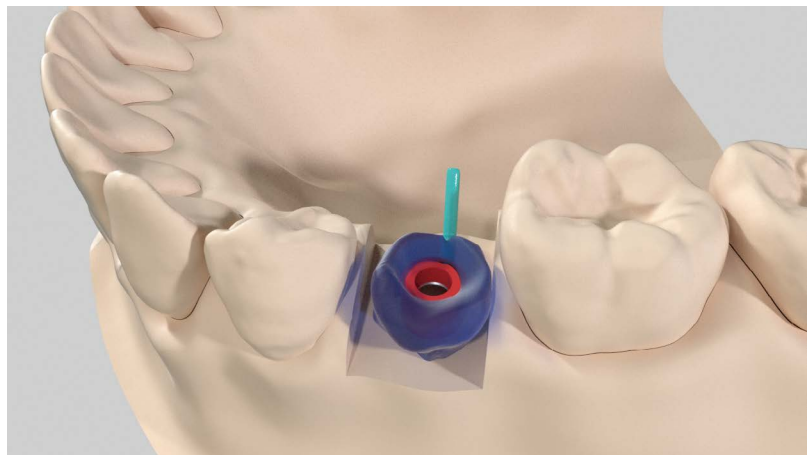

Lab Side

Step 7

Casting

The sprue is mounted on the margin, when forming a sprue for casting,

The Abutment metal part and the adjacent connection part are compensated with wax as much as possible.

It is recommended to use Ni-Cr alloy for casting metal.

Prohibition of use of Co-Cr alloy (excessive oxide film formation and casting shrinkage)

The design parameters for the CCM Cast Abutment

| | |
|---------------------------------|-------------|
| Post Height | 10mm |
| Gingiva Height (min/max) | 1.0mm/3.0mm |
| Angulation | 0° |

CCM Cast Abutment has different casting characteristics compared to Gold UCLA Abutment, so an oxide film is generated on the metal part after casting.



Porcelain build up

Porcelain building up and firing on the casting

Polishing and polishing working in general

Checking if there is anything wrong with the working model

Removal of oxide film generated during casting and porcelain firing

- ① Block out with utility wax, etc., except for the metal part where the oxide film is generated.
- ② Primary removal of oxide film by blasting with a glass bead (4~6 bar) :
Do not use rubber wheel / point (damage to the connection part)

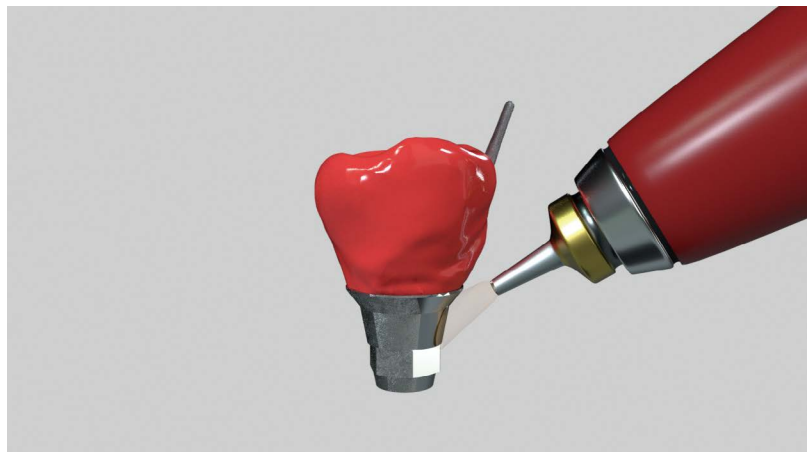

Lab Side

Step 9

Oxide film removal

- ① Remove the blocked out part : Final removal of oxide film by high polishing with rouge applied to cotton
- ② After high polishing, Ultrasonic or steam cleaning.



Step 10

Fastening of intraoral Abutment & installation of prosthesis

Place the Abutment into the oral cavity accurately and fasten the Abutment with a 1.2 Hex Driver.

The correct connection between the Abutment and the Fixture is confirmed by X-ray.

The final tightening is tightened to 30Ncm (to be tightened according to the recommended tightening torque value guided by Abutment) using a 1.2 Hex Driver and a Torque Wrench.

After checking the passive fit of the prosthesis margin, proper contact with the adjacent teeth, and occlusion with the antagonist teeth, block-out the screw hole and cement the final prosthesis on the Abutment.

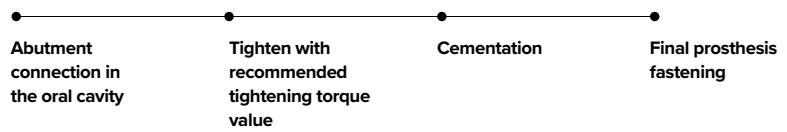

1.2 Hex Driver



Torque Wrench



CCM Cast Abutment



Prosthetic Flow Chart

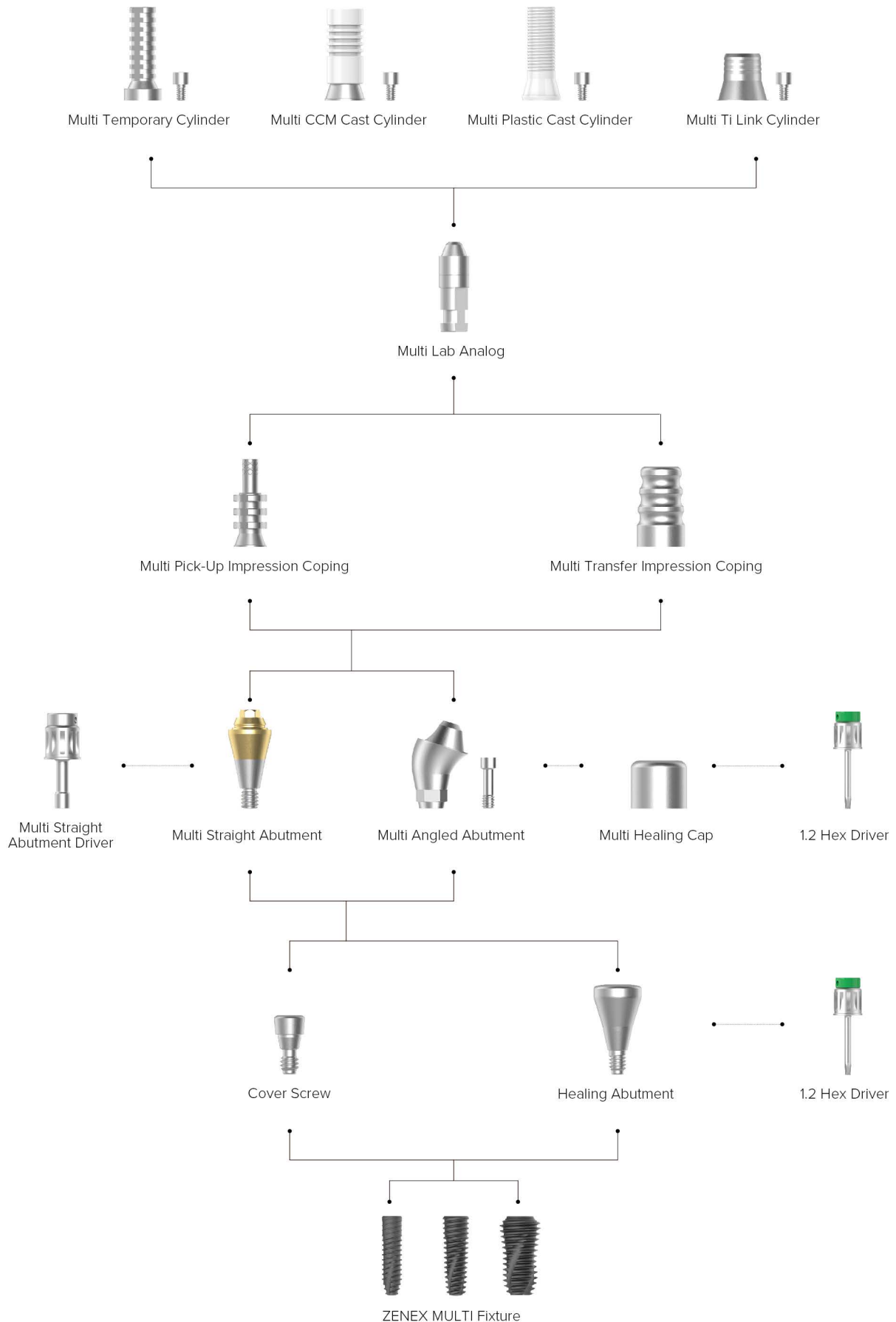

MULTI STRAIGHT & MULTI ANGLED ABUTMENT

Prosthetic Process

- 74 **Step 1** Separation of Cover Screw or Healing Abutment
- 75 **Step 2** Connect the Multi Straight & Multi Angled Abutment in the oral cavity
- 76 **Step 3** Connect the Impression Coping
- 77 **Step 4** Impression Taking
- 78 **Step 5** Working Model Production
- 79 **Step 6** Wax-Up
- 80 **Step 7** Casting
- 81 **Step 8** Porcelain build up
- 82 **Step 9** Oxide film removal
- 83 **Step 10** Ceramic Crown Production
- 84 **Step 11** Delivering & Screwing



Multi Straight Abutment

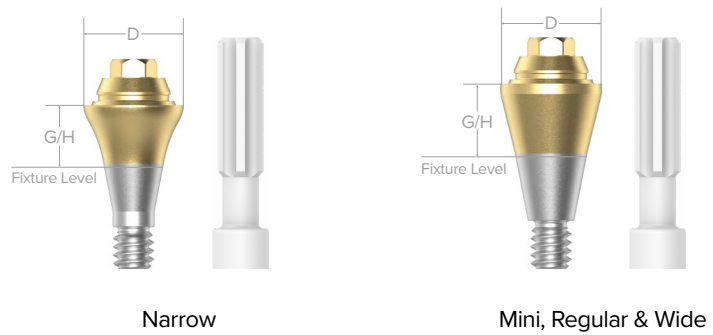

Abutment for manufacturing screw-retained prosthesis in Multiple Case

Same platform as Multi Angled Abutment

Move into internal oral part by using exclusive Abutment Carrier
(Code: MSACR48)

Tighten with exclusive driver (Code: MSADSR20)

Recommended tightening torque: 30Ncm

Multi Angled Abutment

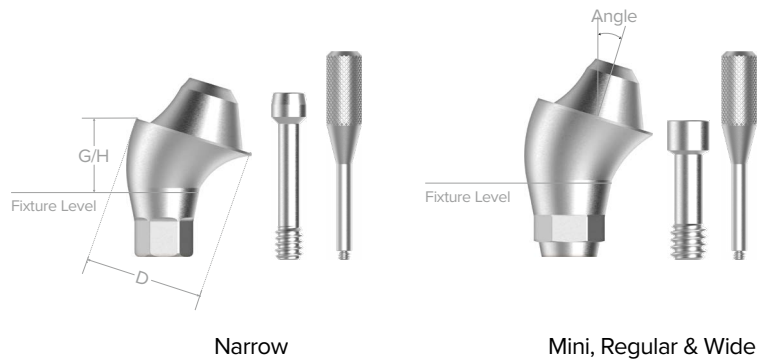

Abutment for manufacturing screw-retained prosthesis in Multiple Case

Abutment of various angles (17°, 30°) for various angled of implant insertion path

Same platform as Multi Straight Abutment

Connect by using exclusive Abutment Carrier (Code: MAACRMC)

Tighten with 1.2 Hex Driver

Recommended tightening torque: 30Ncm

Multi Angled Abutment Screw (MAASTM20 for Narrow & MAASSR23 for Mini, Regular and Wide) included

Step 1 

Separation of Cover Screw or Healing Abutment

Remove Cover Screw or Healing Abutment with 1.2 Hex Driver. At this time, connect dental floss to the spinner in the handle part of the Driver so that the Driver does not pass to the patient's neck. And prepare Impression Coping for the connection of the Fixture.

Healing Abutment



Cover Screw



Multi Straight



Multi Angled



Step 2



Connect the Multi Straight & Multi Angled Abutment in the oral cavity

After connecting the Multi Straight Abutment to the Fixture with the Multi Straight Abutment Driver, check the connection between the Abutment and the Fixture with X-ray, and tighten it with 30Ncm using a Torque Wrench.

Multi Straight



After connecting the Multi Angled Abutment to the Fixture with a 1.2 Hex Driver, check the connection between the Abutment and the Fixture with X-ray, and tighten the screw with 30Ncm using a Torque Wrench.

Multi Angled



Step 3

Connect the Impression Coping

Multi Transfer Impression Coping

Using 1.2 Hex Driver, connect Multi Transfer Impression Coping to Abutment.

Multi Transfer Impression Coping



Multi Straight



Multi Angled



Check the exact contact between the impression Coping and the Abutment with X-ray.



Step 4

Impression Taking

(Abutment level Impression taking)

Multi Lab Analog



Multi Transfer Impression Coping

After injecting the impression material using an Injection syringe around the Coping, the tray filled with the impression material is placed in the oral cavity to obtain an accurate impression.

After removing blood marks and other residues deposited in the impression body, separate the intraoral Multi Transfer Impression Coping and connect it to the Multi Lab Analog.

After contacting the connected Coping and Analog with the Transfer Impression Coping in the impression body, confirm the cross section accurately and deliver it to the Lab.

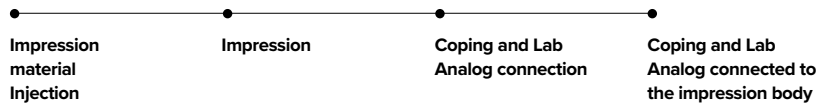

Multi Straight

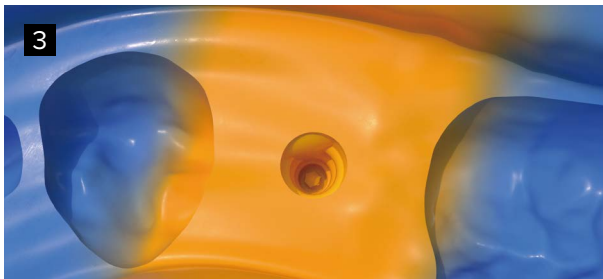
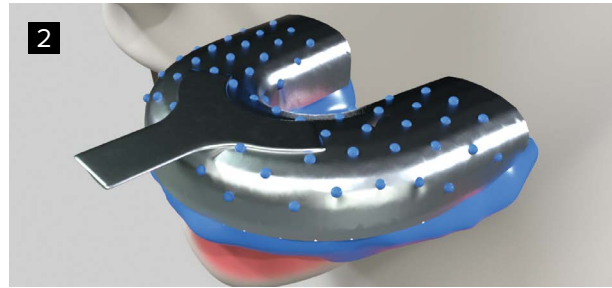

Multi Angled

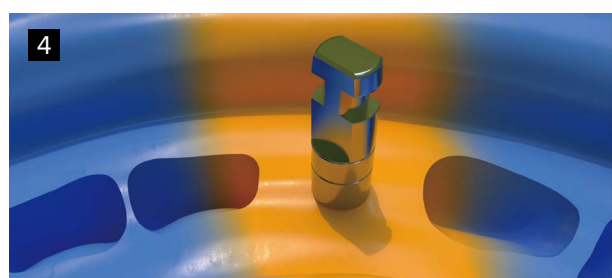
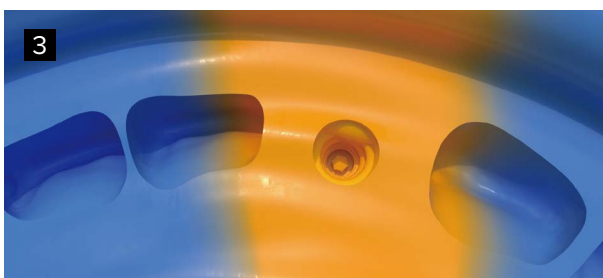
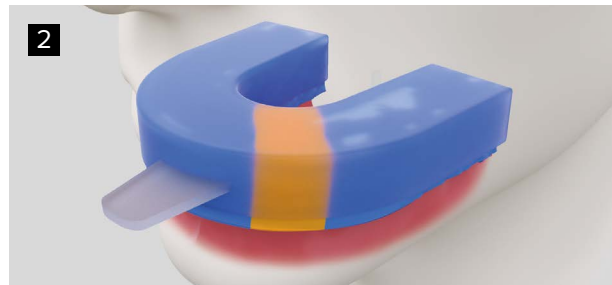

Lab Side

Step 5

Working Model
Production

Tighten the Multi Healing Cap to protect the Abutment until the prosthesis is installed.

Checking whether the Coping is well located in Multi Lab Analog.

After injecting artificial gum around the Analog, when it is hardened, pour stone to make a working model.

Multi Healing Cap



Multi Straight



Multi Angled



Step 6

Wax-Up

Place the Multi CCM Cast Cylinder above the Abutment and fasten the cylinder screw with 20Ncm using a 1.2 Hex Driver.

After adjusting the plastic sleeve to the appropriate height, perform wax-up for the metal structure of the prosthesis.

Multi CCM Cast Cylinder

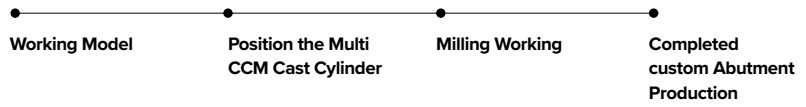

Multi Straight

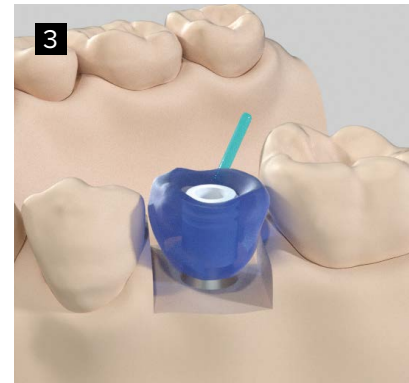
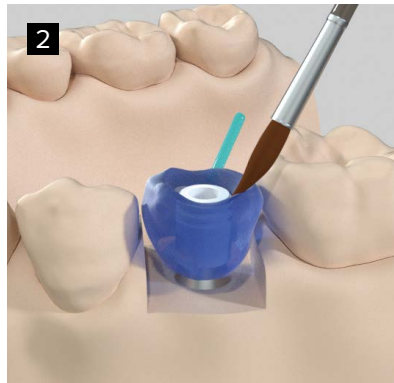

Multi Angled

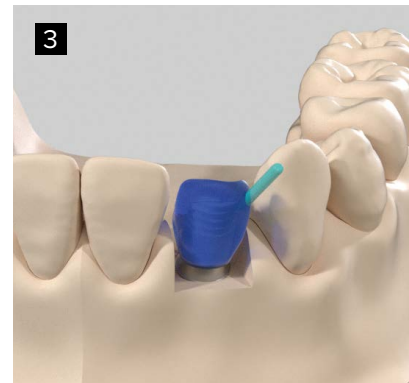
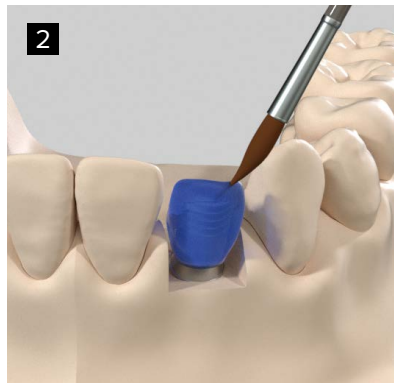

Lab Side

Step 7

Casting

The sprue is mounted on the margin, when forming a sprue for casting,

The Abutment metal part and the adjacent connection part are compensated with wax as much as possible.

It is recommended to use Ni-Cr alloy for casting metal.

Prohibition of use of Co-Cr alloy (excessive oxide film formation and casting shrinkage)

CCM Cast Abutment has different casting characteristics compared to Gold UCLA Abutment, so an oxide film is generated on the metal part after casting.

Multi Straight



Multi Angled



Step 8

Porcelain build up

Porcelain building up and firing on the casting

Polishing and polishing working in general

Checking if there is anything wrong with the working model

Removal of oxide film generated during casting and porcelain firing

- ① Block out with utility wax, etc., except for the metal part where the oxide film is generated.
- ② Primary removal of oxide film by blasting with a glass bead (4~6 bar) :
Do not use rubber wheel / point (damage to the connection part)

Multi Straight



Multi Angled

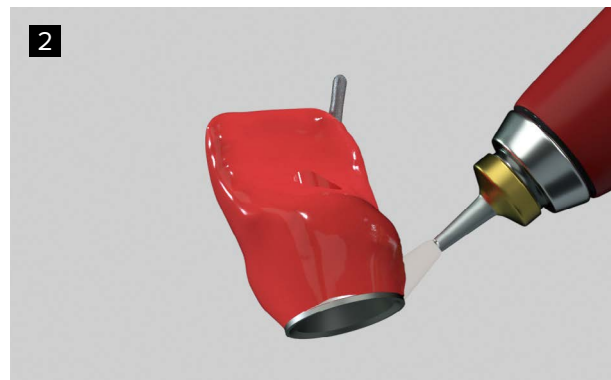

Lab Side

Step 9

Oxide film removal

- ① Remove the blocked out part : Final removal of oxide film by high polishing with rouge applied to cotton
- ② After high polishing, Ultrasonic or steam cleaning.

Multi Straight



Multi Angled



Ceramic Crown Production

The planned ceramic prosthesis is fabricated in the usual way.

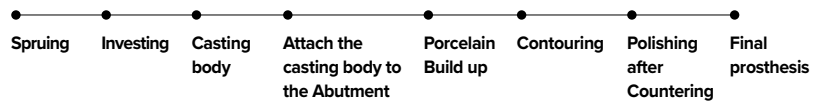

Multi Straight



Multi Angled



Step 11

Delivering & Screwing

After checking the margin passive fit of the final prosthesis and checking occlusion and esthetics, first fasten with a 1.2 Hex Driver and a torque wrench with a 1.2 Hex Driver to completely fasten the prosthesis with 20Ncm.

After covering the protective material over the screw head, the access hole finishes the occlusal surface with resin in the oral cavity.

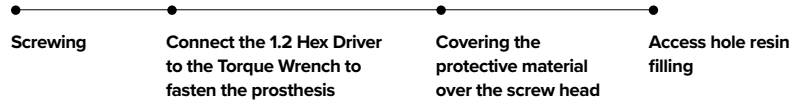

1.2 Hex Driver



Torque Wrench



Multi Straight



Multi Angled



Prosthetic Flow Chart

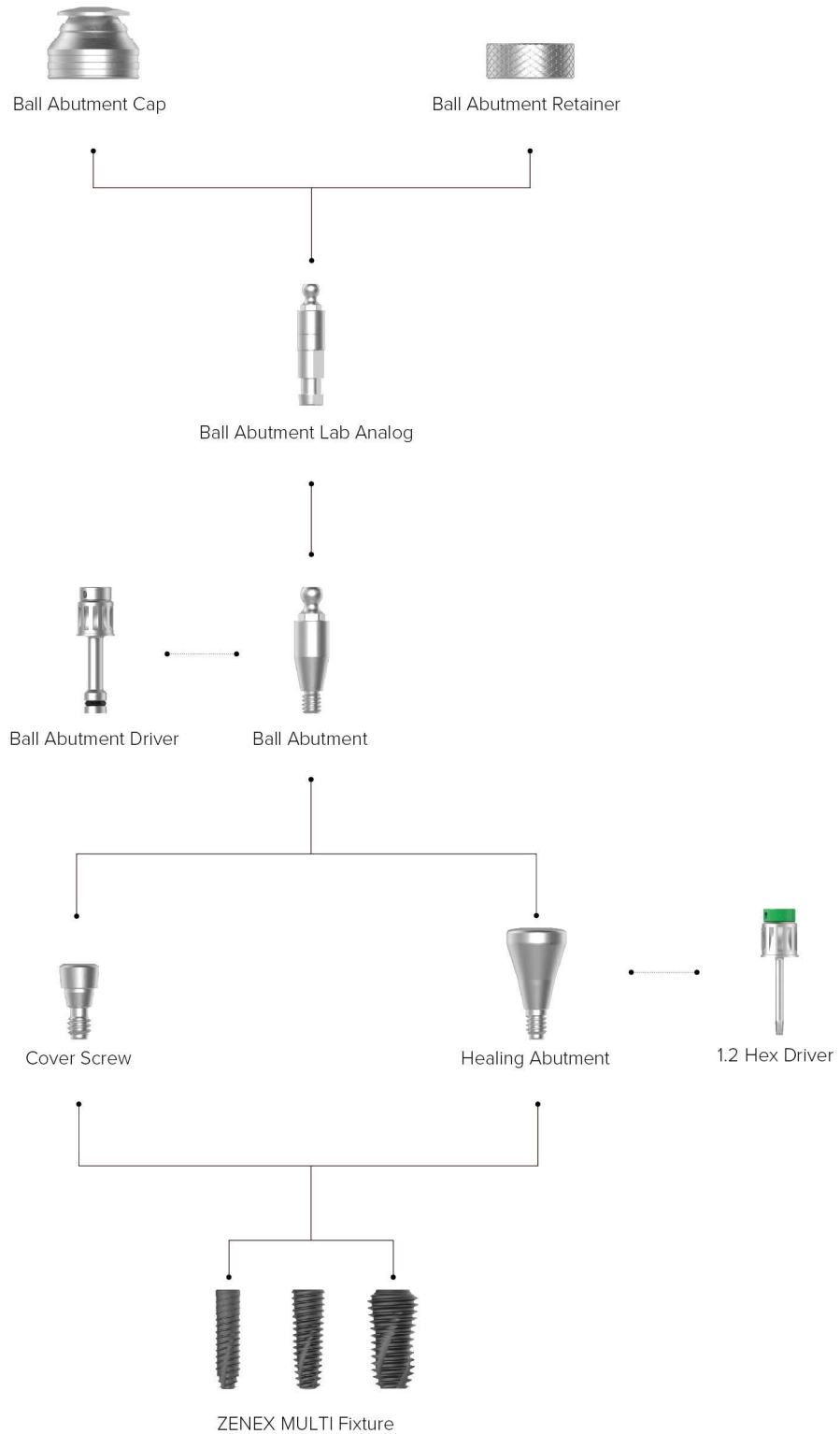

BALL ABUTMENT



Prosthetic Process

- 89 **Step 1** Separation of Cover Screw or Healing Abutment
- 90 **Step 2** Connect the Ball Abutment in the oral cavity
- 91 **Step 3** Impression Taking
- 92 **Step 4** Working Model Production
- 92 **Step 5** Wax Denture Production
- 93 **Step 6** Resin denture Production
- 95 **Step 7** Delivering

Ball Abutment

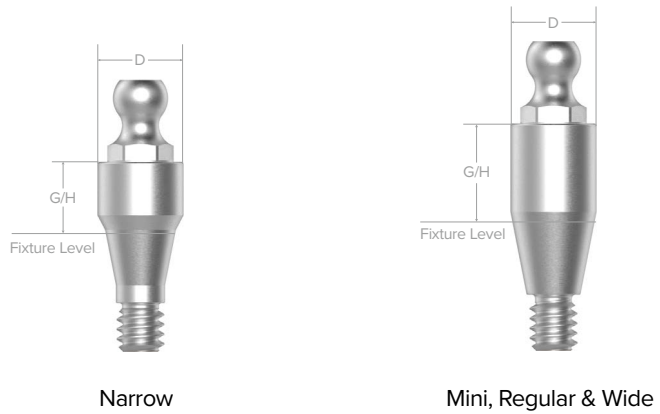

Abutment for overdenture using O-ring attachment

Compensation of mounting angle up to 20°

Tighten with exclusive Ball Abutment Driver (Code: BAD24)

Recommended tightening torque: 30Ncm

Step 1



Separation of Cover Screw or Healing Abutment

Remove Cover Screw or Healing Abutment with 1.2 Hex Driver. At this time, connect dental floss to the spinner in the handle part of the Driver so that the Driver does not pass to the patient's neck. And prepare Impression Coping for the connection of the Fixture.

Healing Abutment



Cover Screw



1.2 Hex Driver



Step 2



Connect the Ball Abutment in the oral cavity

Determine the proper height of the Ball Abutment by measuring the depth of the gingival tissue on the Fixture.

The shoulder of the Abutment should be positioned above the tissue (about 1.5-2mm).

Connect the Ball Abutment to the Fixture with the Driver for Ball Abutment.

After confirming by X-ray, connect the Torque Wrench to the Ball Abutment Driver and tighten it to 30Ncm. (※ When re-fastening the Healing Abutment after taking an impression, fasten it only with finger pressure.)

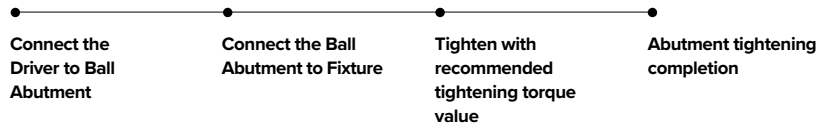

Ball Abutment



Ball Abutment Driver



Torque Wrench



Step 3



Impression Taking

The rubber impression material is first injected in detail around the Ball Abutment, and then the impression material is filled in the prepared individual tray and placed in the oral cavity to obtain an impression.

After checking for abnormalities in the impression body, send it to the lab.

If there is a denture currently installed, it can be used as a Temporary denture by modifying the part where the Ball Abutment is fastened.



Preliminary procedure: Before installing the Ball Abutment, take an impression of the edentulous extension with alginate impression material and send it to the workshop to make a personal tray (※ 2mm more relief than the height of the Abutment).

Scratch is formed on the border so that the impression material can be attached well.

Ball Abutment Lab Analog

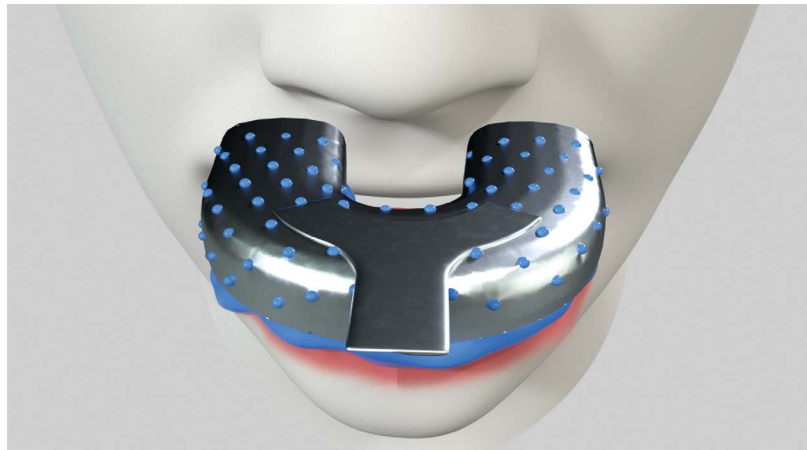

Lab Side

Step 4

Working Model Production

When the impression body is delivered for the pore process, the lab Analog is pushed into the inner surface of the impression body until it is completely inserted into the Ball portion.

Make a working model by carefully pouring stone so that the Analog position does not move.

Base plate and wax occlusal rim for occlusal acquisition are made and sent to the clinic with the model.

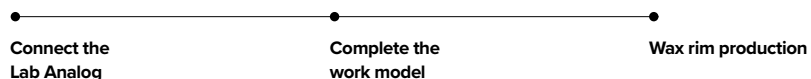

Lab Side

Step 5

Wax Denture Production

The occlusal rim is placed in the oral cavity to obtain an intermaxillary occlusion and sent back to the studio.

In the workshop, denture teeth are arranged on the wax rim according to the occlusal record sent.

It is sent back to the doctor's office to check the occlusion of the arranged teeth and check the functionality and aesthetics of the denture.

(※ If corrections are made, set up a new occlusal record and retry until fit is achieved.)

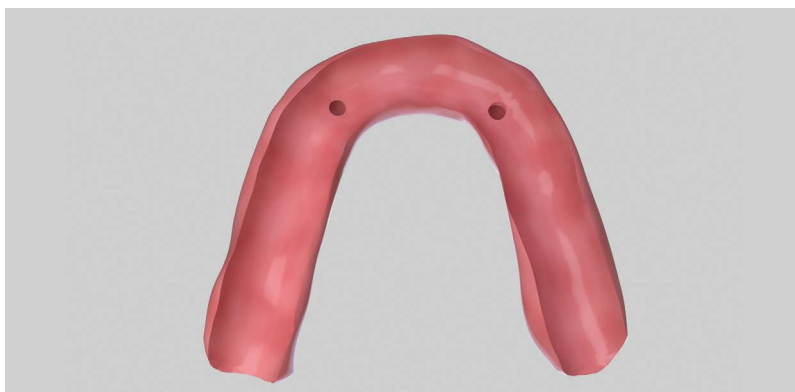

Step 6

Resin denture Production

When the oral fit for the wax denture is completed, the final resin denture is fabricated.

Check the black Lab O-ring in the Ball Abutment Retainer or Ball Abutment Cap (※ Make the smaller of the Ball Abutment Retainer openings be the occlusal side) and place it on the Lab Analog.

Block-out the lower part of the retainer with a putty to prevent the acrylic resin from flowing under the Ball Abutment Retainer, and make it about 2mm higher than the retainer to give mobility on the denture base.

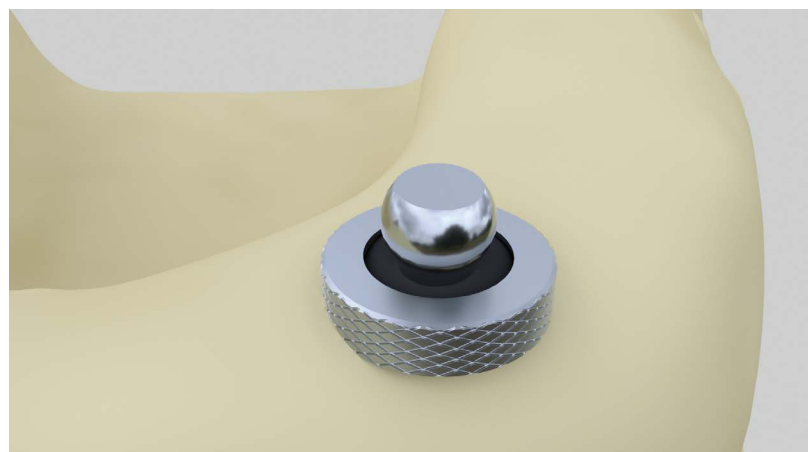
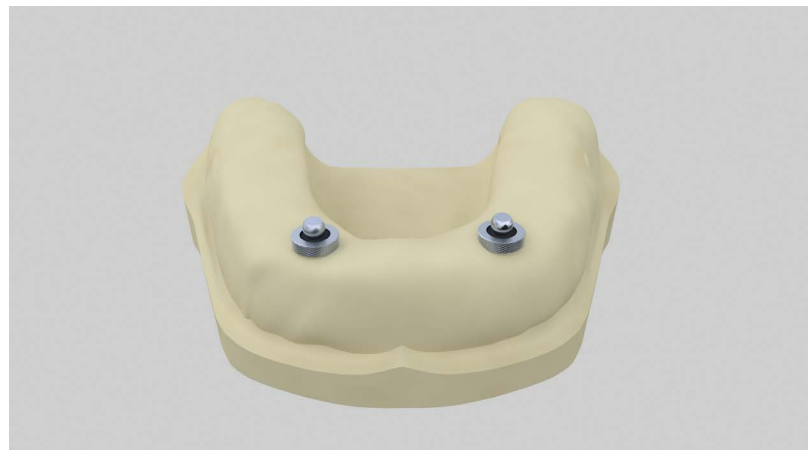
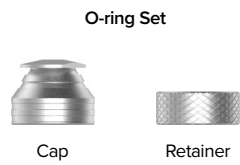
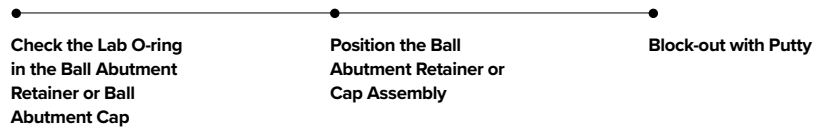

Step 7

Delivering



Replace the Black Lab O-ring inside the Ball Abutment Retainer with the orange O-ring for final.

Adjust occlusal and tissue contact areas as needed.

While attaching attachments, inform the patient about oral hygiene and cautions when attaching and detaching dentures.

Replace O-rings when fatigue accumulates and cannot function.

It is replaced approximately once a year.



O-ring



Prosthetic Flow Chart

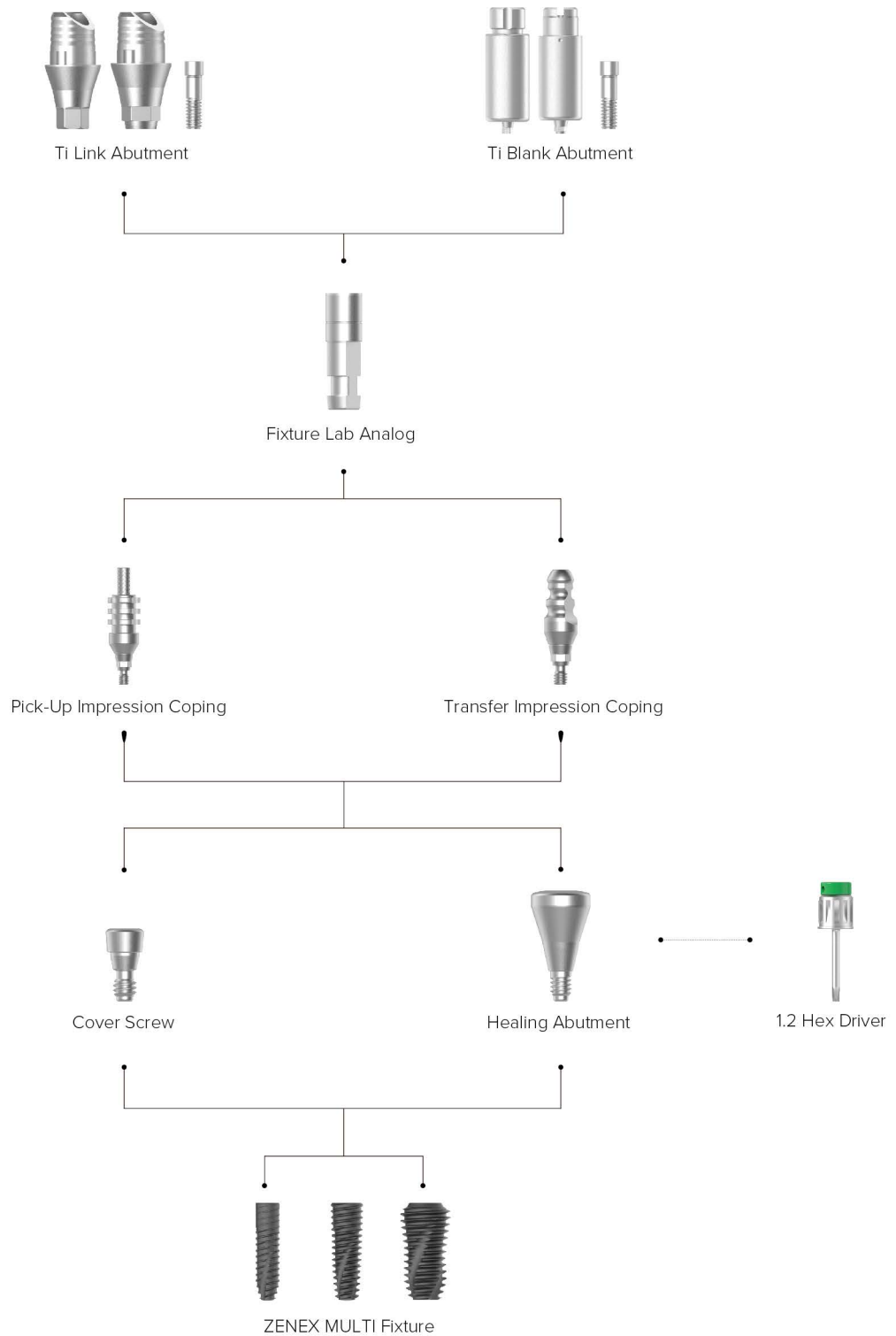

TI LINK ABUTMENT

Prosthetic Process

- 99 Step 1** Separation of Cover Screw or Healing Abutment
- 99 Step 2** Impression Taking
- 101 Step 3** Working Model Production
- 102 Step 4** Scan
- 103 Step 5** Design
- 103 Step 6** Design confirm and processing
- 104 Step 7** Sintering and post-processing
- 105 Step 8** Bonding and completion of Abutment
- 106 Step 9** Final prosthesis fabrication
- 106 Step 10** Fastening of intraoral Abutment & installation of prosthesis



Ti Link Abutment

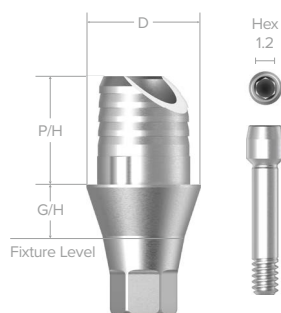

Narrow

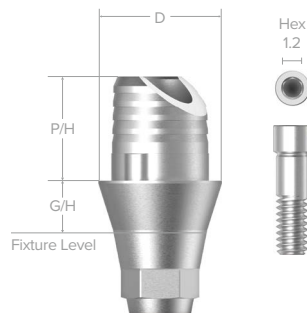

Mini, Regular & Wide

Abutment Features

Possible to correct path when manufacturing prosthesis by realizing a cross section with a slope at the top of the product.



Abutment for manufacturing Cement/Combination-retained type prosthesis

For manufacturing custom abutment (Titanium & Zirconia) and crown by CAD/CAM equipment

Select specification fits for fixture Connection

Use digital library for ZENEX Implant System

Fixture Level Impression

Tighten with 1.2 Hex Driver

Recommended tightening torque: 30Ncm

Step 1

Separation of Cover Screw or Healing Abutment

Healing Abutment



Cover Screw



Remove Cover Screw or Healing Abutment with 1.2 Hex Driver. At this time, connect dental floss to the spinner in the handle part of the Driver so that the Driver does not pass to the patient's neck. And prepare Impression Coping for the connection of the Fixture.



Step 2

Impression Taking

1.2 Hex Driver



Pick-up Impression Coping



Consider the Abutment diameter and type to be used (Hex/Non-Hex)

Selection of Impression Coping specifications (Pick-up Impression Coping / Transfer Impression Coping)

Fastening the Pick-up Impression Coping by hand using a 1.2 Hex Driver

Block out the Pick-up Impression Coping coping's driver hole recommended



After fastening, be sure to take an apical X-ray to check the correct seating



Impression taking by injecting impression material from around the Impression Coping

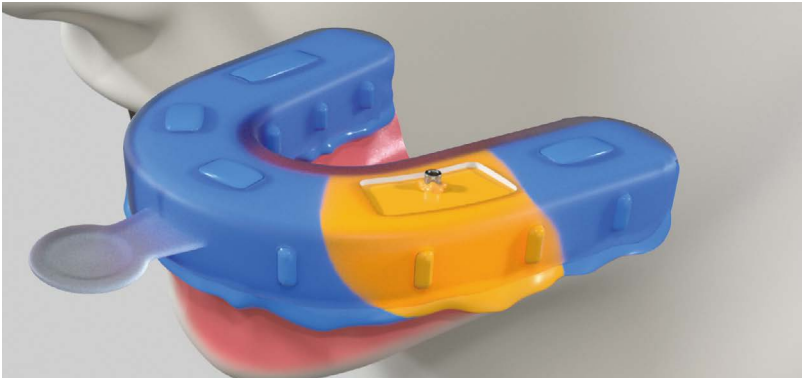

Working Model Production

Lab Analog



After passing the body making impressions in the doctor's office after checking the correct fastening of the Lab Analog form an Artificial Gum around Analog, and injecting the anhydrite is produced by the Working Model.

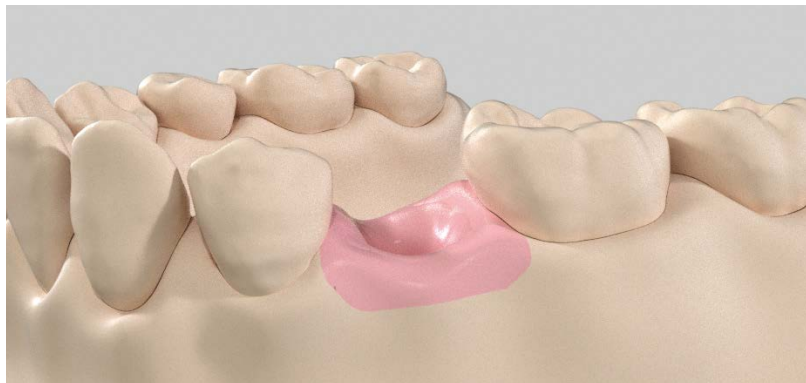
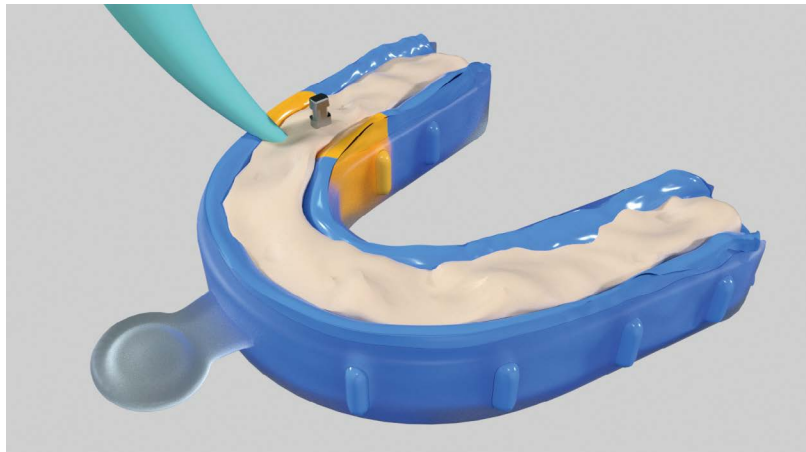
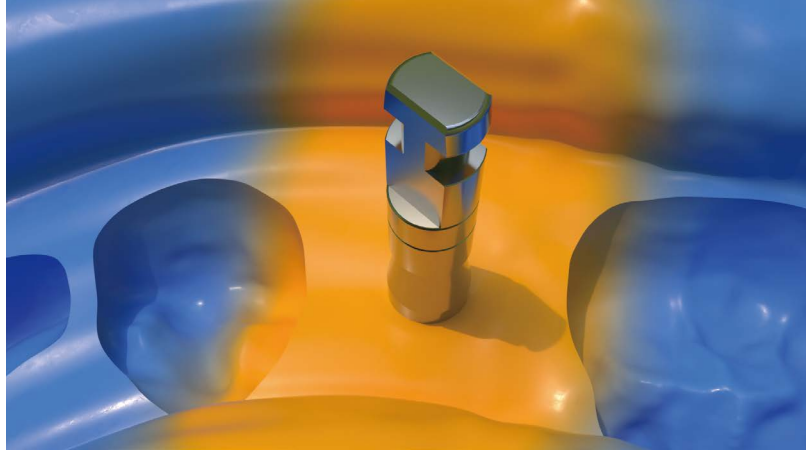

Lab Side

Step 4

After attaching the Scanbody to the working model, it creates digital data through scanning

Scan

Scanbody



Lab Analog

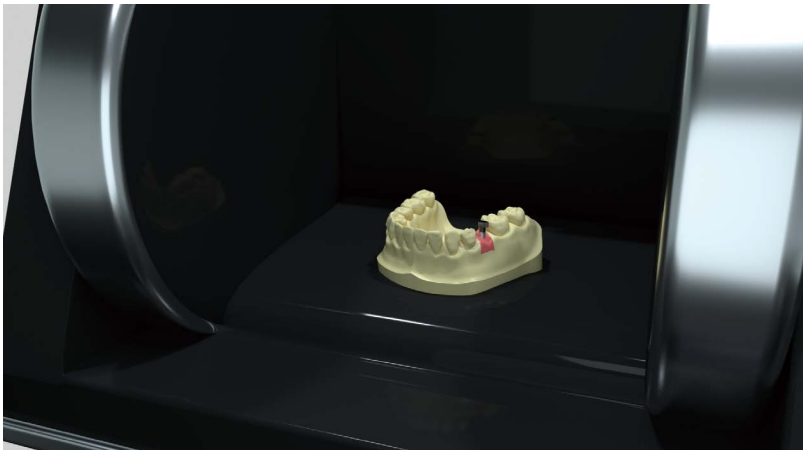

Step 5

Design

The library data and manual of the digital library S/W can be downloaded from the Izenimplant website.

Education-Learning Digital Dentistry on the website(For Exocad, 3shape)

After calling and matching the scan file on S/W, Abutment design based on the order form

For cement type prosthesis production, the final prosthesis shape is predicted and designed in the form of coping.

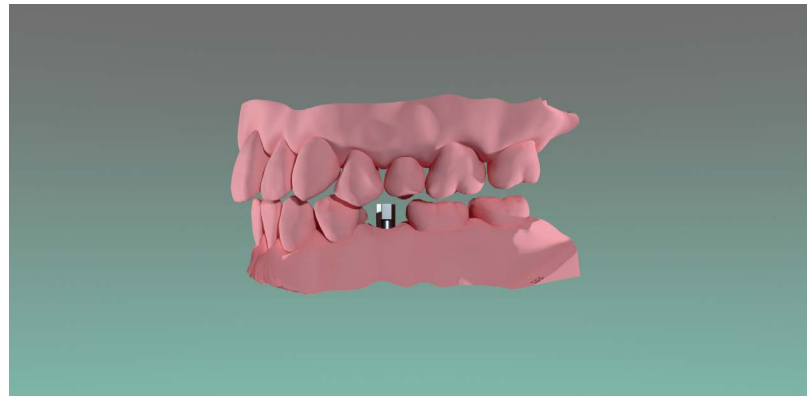

Step 6

Design confirm and processing

Final design and file confirmation and processing

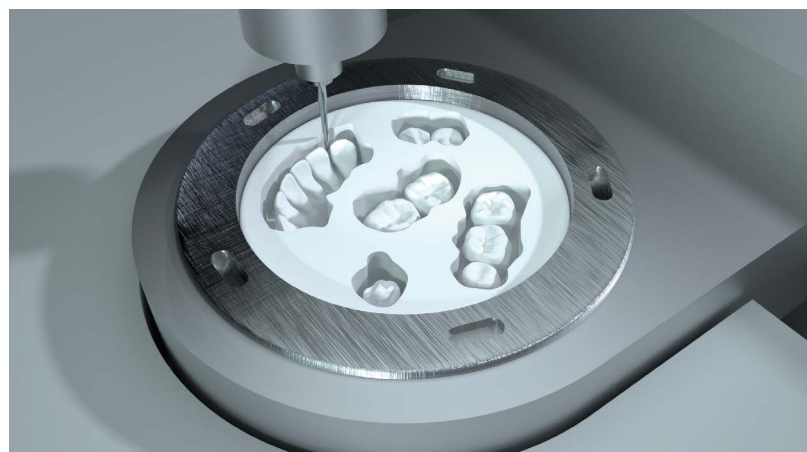

Lab Side

Step 7

Sintering and post-processing

Processed zirconia coping body sintering

Ti Link Abutment is sand blasted only the adhesive part

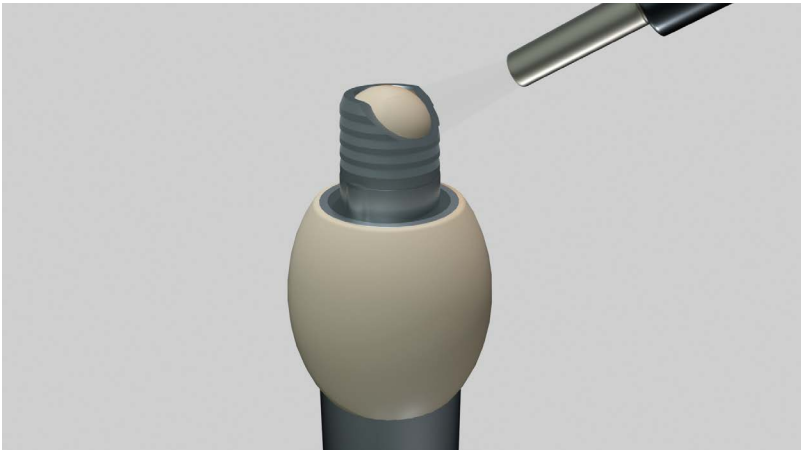
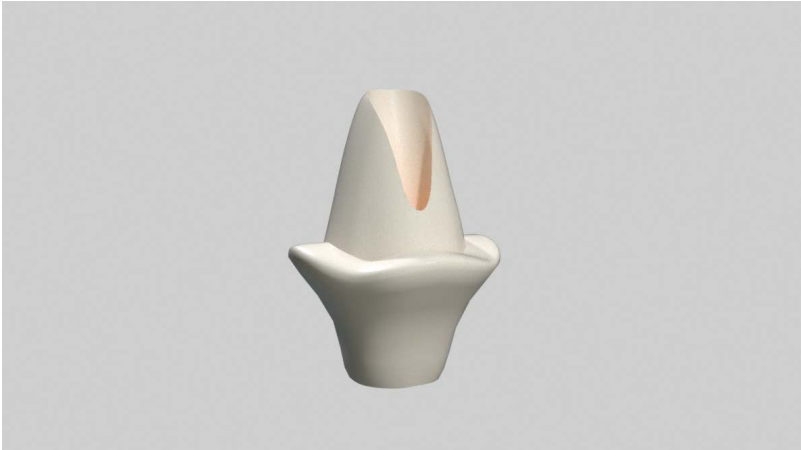

Bonding and completion of Abutment

Bonding cleaned Ti Link Abutment and zirconia coping body

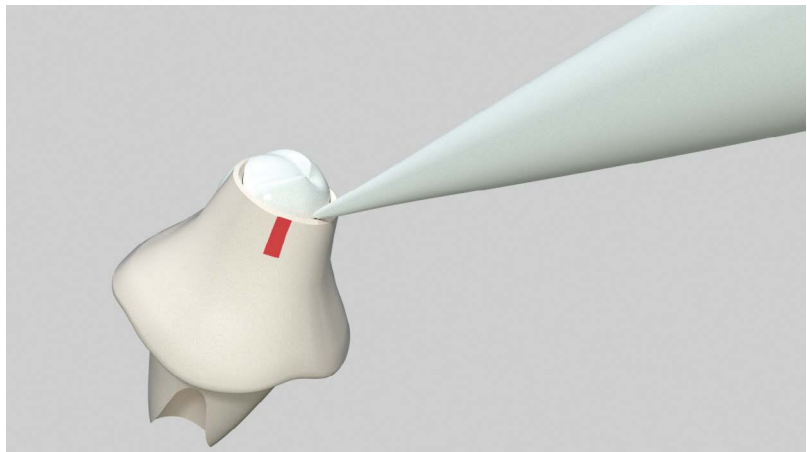
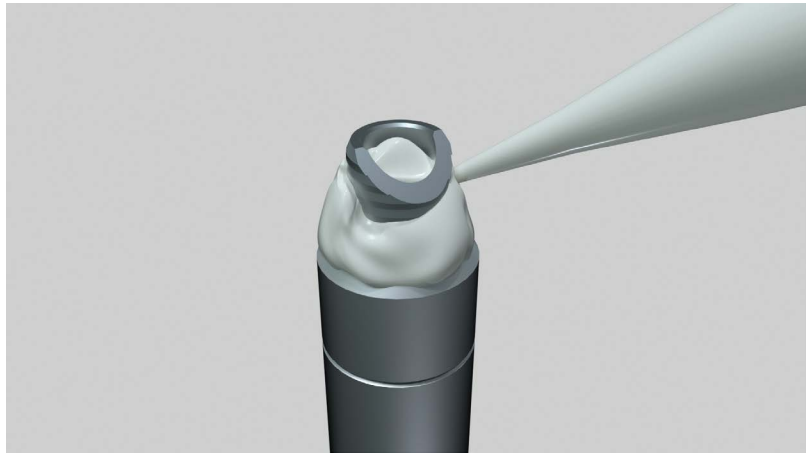

Lab Side

Step 9

Final prosthesis fabrication

Fabricate the final prosthesis.



Step 10

Fastening of intraoral Abutment & installation of prosthesis

Place the Abutment into the oral cavity accurately and fasten the Abutment with a 1.2 Hex Driver.

The correct connection between the Abutment and the Fixture is confirmed by X-ray.

The final tightening is tightened to 30Ncm (to be tightened according to the recommended tightening torque value guided by Abutment) using a 1.2 Hex Driver and a Torque Wrench.

1.2 Hex Driver



Torque Wrench



TI BLANK ABUTMENT

Prosthetic Process

- 109 **Step 1** Separation of Cover Screw or Healing Abutment
- 109 **Step 2** Impression Taking
- 111 **Step 3** Fastening of Healing Abutment or Production of Temporary Abutment
- 112 **Step 4** Working Model Production
- 112 **Step 5** Scan
- 113 **Step 6** Design
- 113 **Step 7** Design Confirm and processing
- 114 **Step 8** Post Processing
- 114 **Step 9** Connect the Customized Abutment
- 114 **Step 10** Wax-up
- 115 **Step 11** Casting
- 115 **Step 12** Ceramic Crown Product
- 116 **Step 13** Fastening of intraoral Abutment & installation of prosthesis



Ti Blank Abutment

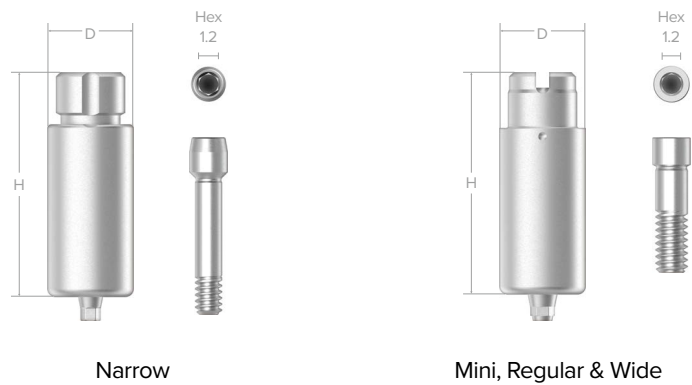

Manufacturing customized abutment with milling machine

Select specification fits for fixture Connection

Digital Impression

Tighten with 1.2 Hex Driver

Recommended tightening torque: 30Ncm

Product line-up applied for various milling machine brands
(Milling machine manufacturer: Arum, Manix, Vatech, RND)

Step 1

Separation of Cover Screw or Healing Abutment

Remove Cover Screw or Healing Abutment with 1.2 Hex Driver. At this time, connect dental floss to the spinner in the handle part of the Driver so that the Driver does not pass to the patient's neck. And prepare Impression Coping for the connection of the Fixture.

Healing Abutment



Cover Screw



Step 2

Impression Taking

Consider the Abutment diameter and type to be used (Hex/Non-Hex)
Selection of Impression Coping specifications (Pick-up Impression Coping / Transfer Impression Coping)
Fastening the Healing Abutment by hand using a 1.2 Hex Driver
Block out the Transfer Impression Coping's driver hole recommended

1.2 Hex Driver



Transfer Impression Coping



Pick-up Impression Coping



After fastening, be sure to take an apical X-ray to check the correct seating



Impression taking by injecting impression material from around the Impression Coping

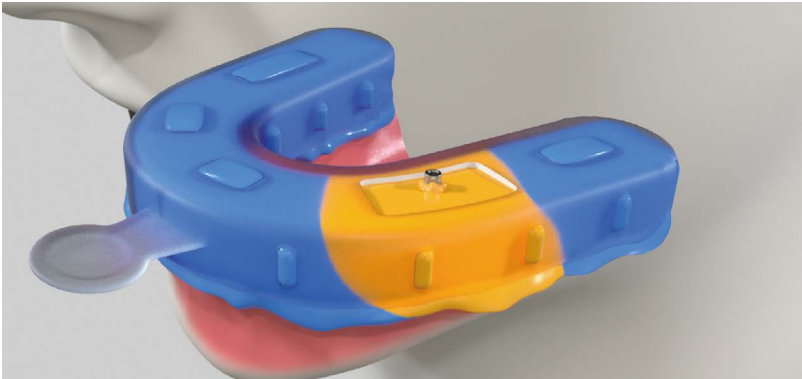

Step 3



Fastening of Healing Abutment or Production of Temporary Abutment

After taking the impression, separate from the Impression Coping oral cavity

Retighten the Healing Abutment to protect the Abutment until the prosthesis is installed

Or the Temporary Abutment production according to the case



Step 4

Working Model Production

After passing the body making impressions in the doctor's office after checking the correct fastening of the Lab Analog form an Artificial Gum around Analog, and injecting the anhydrite is produced by the Working Model.

Lab Analog

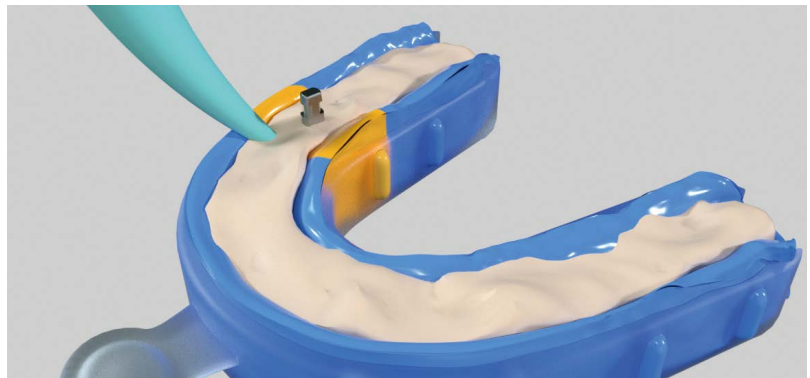

Lab Side

Step 5

Scan

After attaching the Scanbody to the working model, it creates digital data through scanning

Scanbody



After calling and matching the scan file on S/W, Abutment design based on the order form

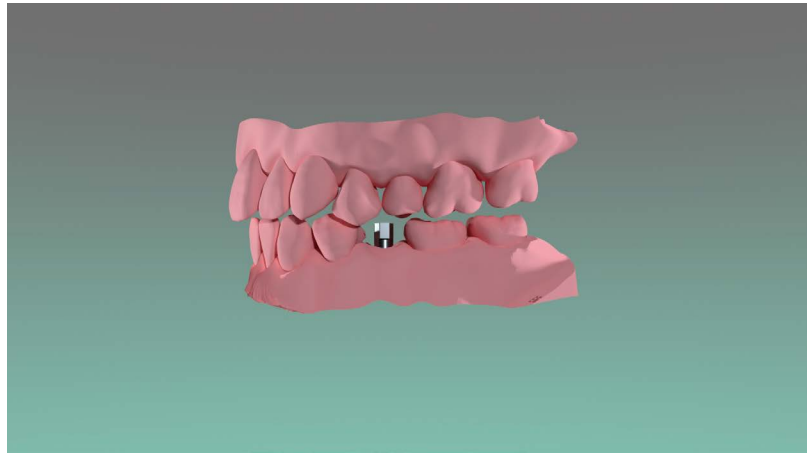

Final modification and processing based on customer's confirmation

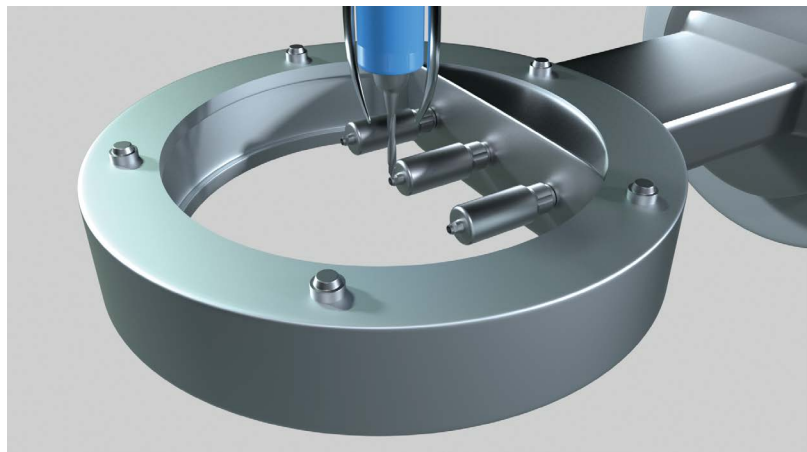
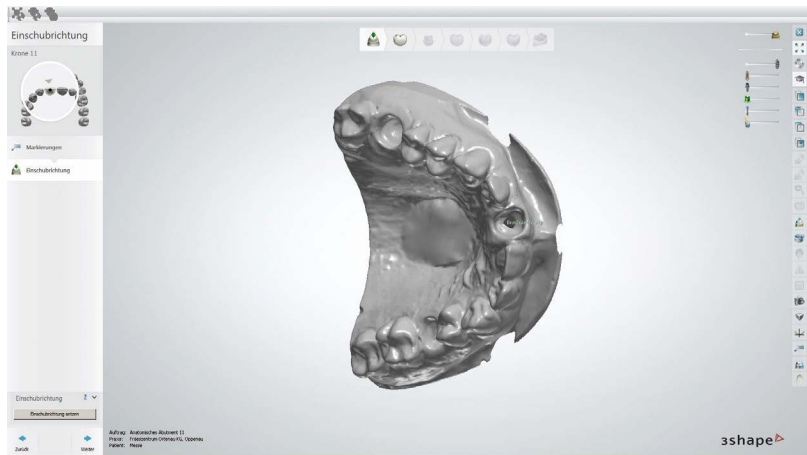

Lab Side

Step 8

Post Processing

After processing, clean and polish



Lab Side

Step 9

Connect the Customized Abutment

After post-processing connect the Customized Abutment to the Lab Analog



Lab Side

Step 10

Wax-up

Wax-up in the usual way

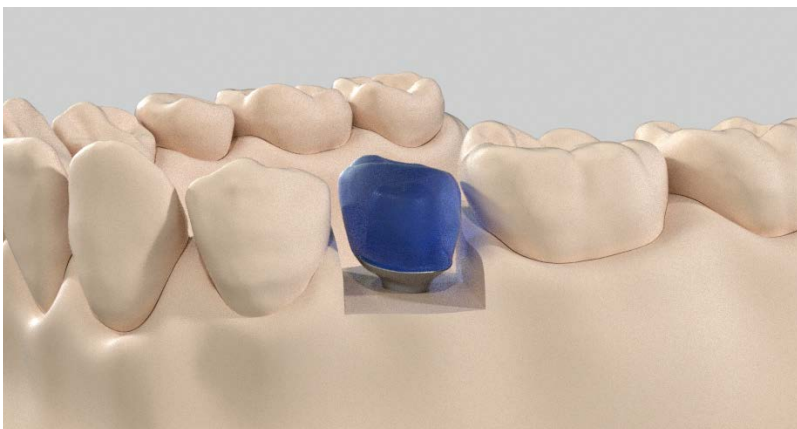

Lab Side

Step 11

Casting

Delete operation for resin facing if necessary

Casting by connecting sprue in the usual way

Post-processing and conformity check for castings



Lab Side

Step 12

Ceramic Crown Product



Step 13

Fastening of intraoral Abutment & installation of prosthesis

Fastening of intraoral Abutment & installation of prosthesis

Checking of prosthesis delivered from the Lab

Remove the Healing Abutment or Temporary prosthesis in the oral cavity

After placing the prosthesis with cement, remove the remaining cement

1.2 Hex Driver



Torque Wrench



IZ-PMA-01 REV.01 (2024-01)



Izenimplant Co., Ltd.
www.izenimplant.com

HQ & Factory

1, 2Dong, 26-32, Suworam 4-gil, Seotan-myeon,
Pyeongtaek-si, Gyeonggi-do, 17703
Republic of Korea

Overseas Business Department

10F 1dong #1011,#1012, #1013, #1014 Central-Tower II,
158, Magokseo-ro, Gangseo-gu, Seoul, 07788
Republic of Korea

Tel. +82-31-662-0657 (HQ)
+82-2-3664-3666 (Sales)
Fax. +82-31-662-0658